

Structural
waterproofing

Ground gas
protection

Ground heave
protection

PRODUCT INSTALLATION TRAINING GUIDE



PREMCRETE

PROTECTING COMPLEX STRUCTURES

JUNE 2026



Premcrete training the know how

This training guide is intended as a guide and does not replace the requirement of installation training on site by a Premcrete technician. Project specific details should always be adhered to as these may vary from illustrations shown. Coverage Guides may differ from official data sheet coverage, to make allowance for the realities on site.



Contents

	CONSTRUCTION JOINTS SERVICE PENETRATIONS Hydrostop BR - Hydrophillic Waterbar Cemflex VB - Active Metal Waterstop Hydrostop RI - Injectable Hose System	05
	MAXIPRUF PLUS High Performance Waterproof Membrane	17
	COMBISEAL HD COMBISEAL PLUS Gas-Resistant Waterproof Membrane VOC-Resistant Waterproof Membrane	23
	HYDROPRUF 6000 & 9000 Flexible Hydrocarbon Resistant Membrane Gas Resistant Damp-Proof Membrane	31
	HYDROPRUF DPM 2000G High Performance Damp-Proof Membrane	37
	HYDROPRUF 3000 & 8000 HYDROFLOW HM8 Self-Adhesive Gas Resistant Membrane Geocomposite Drainage Membrane - vertical	41
	HYDROFLOW HP Cavity Drain Membrane System	47
	HYDROSEAL FX Two-part Cementitious Hybrid-polymer Coating	55
	EPOFLEX MMA HYDROFLOW HM25 Flexible Liquid Waterproof Membrane Geocomposite Drainage Membrane - horizontal	61
	HYDROREND High Performance Waterproof Render	67
	HYDROBAR PVC Waterstop Range	71
	HYDROBAND HP High Performance Thermoplastic Membrane	75
	VOID-TEK Ground Heave Protection System	79
	PREMTRAC Quality Control Portal	87
	CONCRETE POURING & COMPACTION Best Practice Guide	91



CONSTRUCTION JOINTS SERVICE PENETRATIONS

BRINGING YOU THE **KNOWHOW** WHEREVER YOU ARE.

We aim to make substructure protection Knowhow accessible wherever you are - Onsite or Offsite, Online or Offline.

ONSITE



- ◆ Installer practical training sessions
- ◆ Product demonstrations
- ◆ Product trials and testing
- ◆ Quality control training

OFFSITE



- ◆ CPDs
- ◆ Premcrete HQ training facility
- ◆ Product testing & formulation
- ◆ Partnerships with other academies

ONLINE



- ◆ PREMTRAC QC portal & training register
- ◆ Downloadable typical details & data sheets
- ◆ Youtube 'how to' videos
- ◆ Interactive 3D model & online training program

OFFLINE



- ◆ Training manual
- ◆ Training banners
- ◆ Written training programme
- ◆ Offline to online QR codes

Product Glossary

- Products required
- Kicker preparation
- Application of Hydrostop WSM
- Application of Hydrostop BR
- Application of Cemflex VB
- Penetration detailing

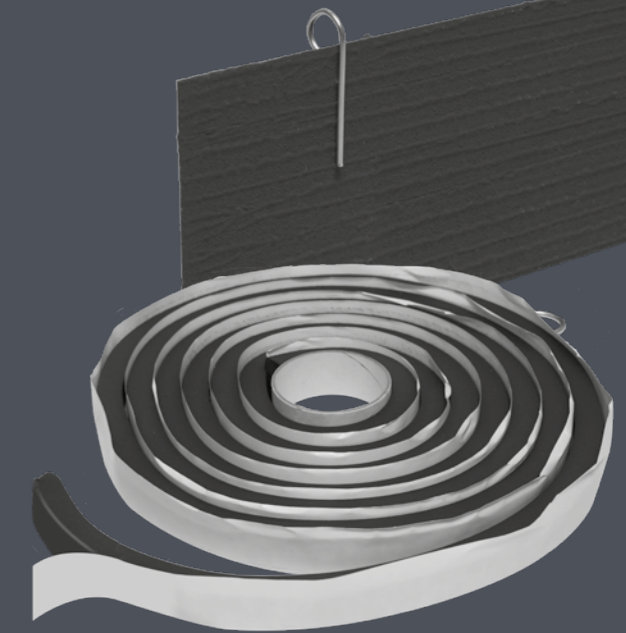

CONTACT US TO REQUEST YOUR TRAINING AND CERTIFICATION SALES@PREMCRETE.COM

SCAN HERE TO VIEW OUR **HYDROSTOP BR** DATA SHEET AND TRAINING VIDEO

SCAN HERE TO VIEW OUR **CEMFLEX VB** DATA SHEET AND TRAINING VIDEO

SCAN HERE TO VIEW OUR **HYDROSTOP RI** DATA SHEET AND TRAINING VIDEO



HYDROSTOP WSM APPLICATION

No rebate in construction joints required for this product.



HYDROSTOP WSM COVERAGE GUIDE

PRODUCT SIZE
600ML SACHET WITH 8MM NOZZLE

COVERAGE
UP TO 8 LINEAR METRES
25 X 3MM BEAD



Insert Hydrostop WSM into applicator gun.

KICKER PREPARATION



Prepare joint to provide a sound substrate free of loose material. Application of Premtard TF / MF is recommended to enable removal of surface laitance with jet-washing to expose aggregate.

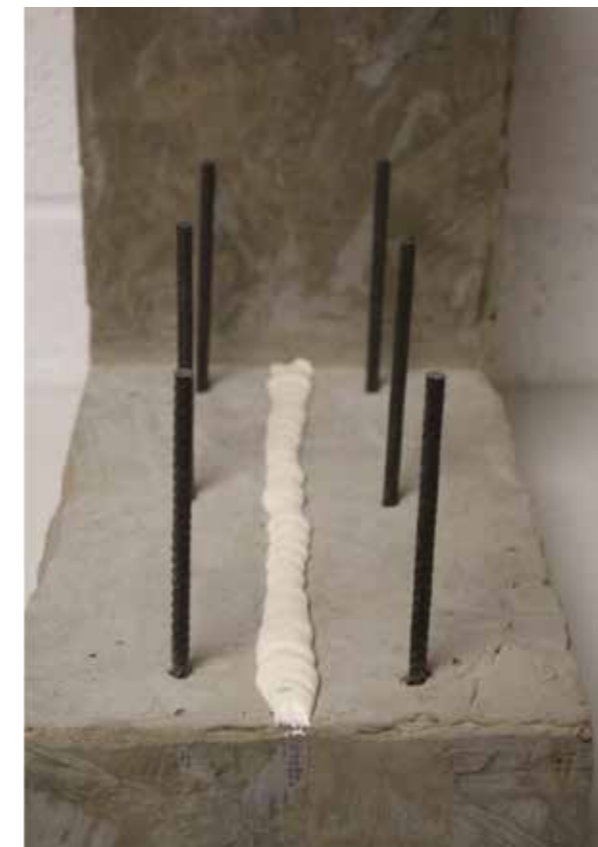

Apply 8mm bead of Hydrostop WSM to substrate.



HYDROSTOP BR APPLICATION

No rebate in construction joints required for this product.



Firmly press the waterbar into Hydrostop WSM and ensure there are no voids below.



Butt joint internal corners to ensure there are no voids behind.



Joints in Hydrostop BR should be overlapped by a minimum of 50mm side-by-side. Install with a minimum of 75mm concrete cover to face of concrete.



Nail waterbar at 300mm centres using Hydrostop retaining pins.

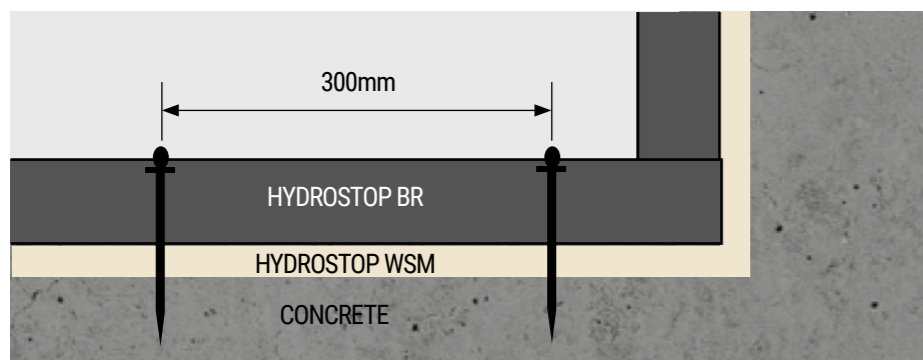

CEMFLEX VB APPLICATION



Cemflex VB should be pre-installed in kicker joint before concrete is cast. This can be hung with tying wire and timber blocks as pictured above, or Omega Holders can be supplied.



Cemflex VB to be secured between starter bars.



Ensure waterbar is installed with 30mm embedment into first pour, leaving 120mm protruding for wall pour.



Overlap waterbar by minimum 150mm ensuring plates are held tightly together. Two Cemflex clips should be used to secure each lap.



Continue waterbar through construction joint by minimum 200mm for lapping to next pour.



Laser level used to ensure correct consistent height.



There must be no gap beneath the Cemflex VB after the first concrete pour.

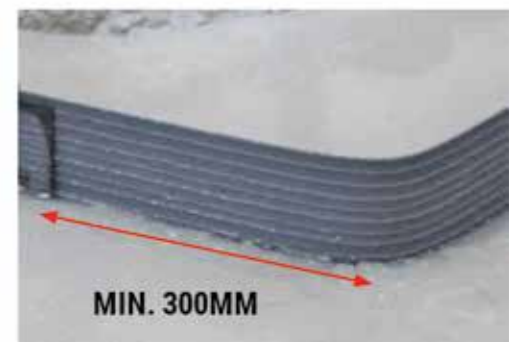

Corners must be bent to follow the construction joint. Cemflex VB must be lapped at least 300mm away from corner.

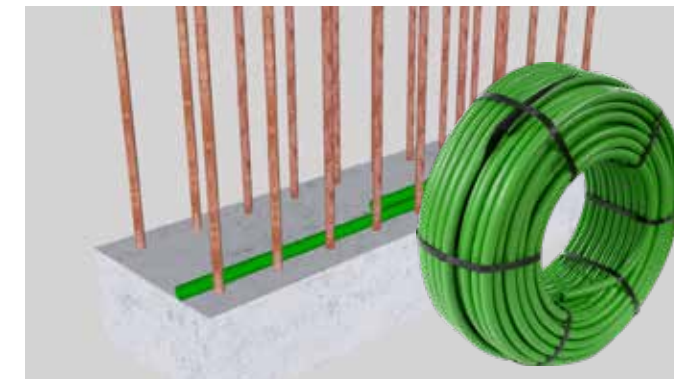

▲ Cut the Hydrostop RI (green hose) into suitable premeasured lengths, typically 10m to 12m, and maximum 15m.

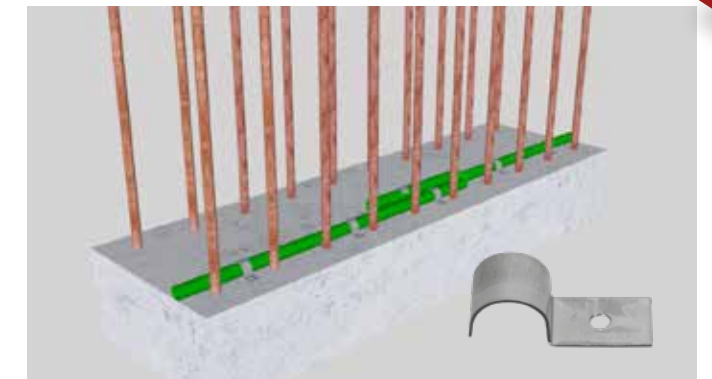

▲ Fasten the hose system to the concrete with the provided hose clamps approximately 15cm (recommended) and up to 30cm centres (depending on the state of the joint and detail). The metal clamps may be fastened with shot fired washer nails. The red and white hoses should not be fixed into position but left free.

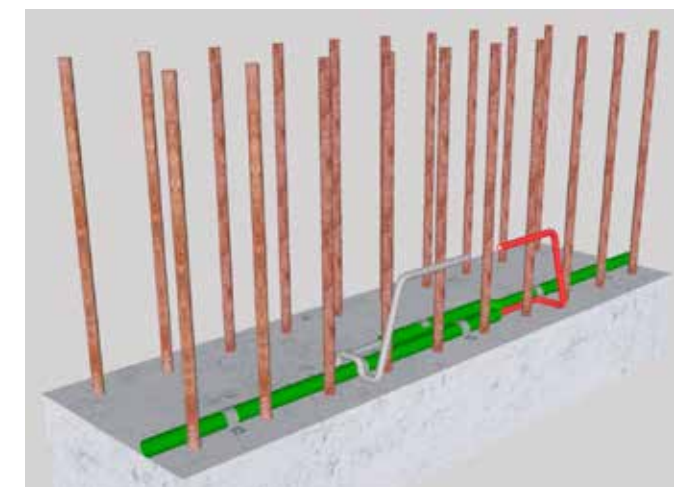

◀ Each length of Hydrostop RI will have an injection hose (red inlet hose) installed at one end and a ventilation hose (white outlet hose) at the other end.

The red and white hoses should be connected to the Hydrostop RI using the hot-shrinking hose (black). Cut a taper on one end of the injection hose (red) and a straight cut at the other end. place some PVC glue over the tapered end of the red hose and insert tightly into the end of the RI green hose. repeat as for the ventilation hose (white).

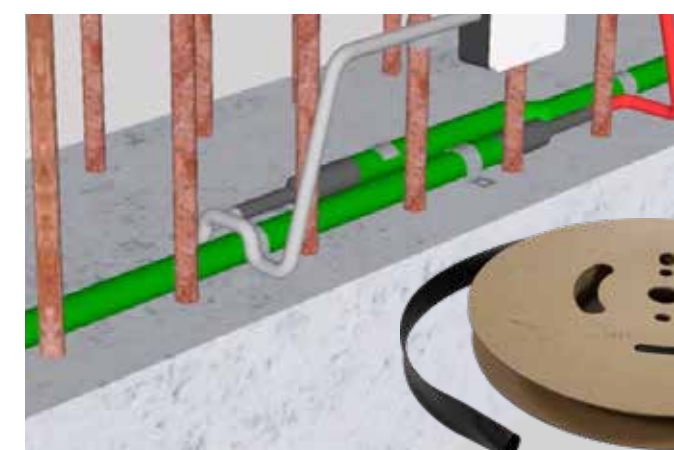
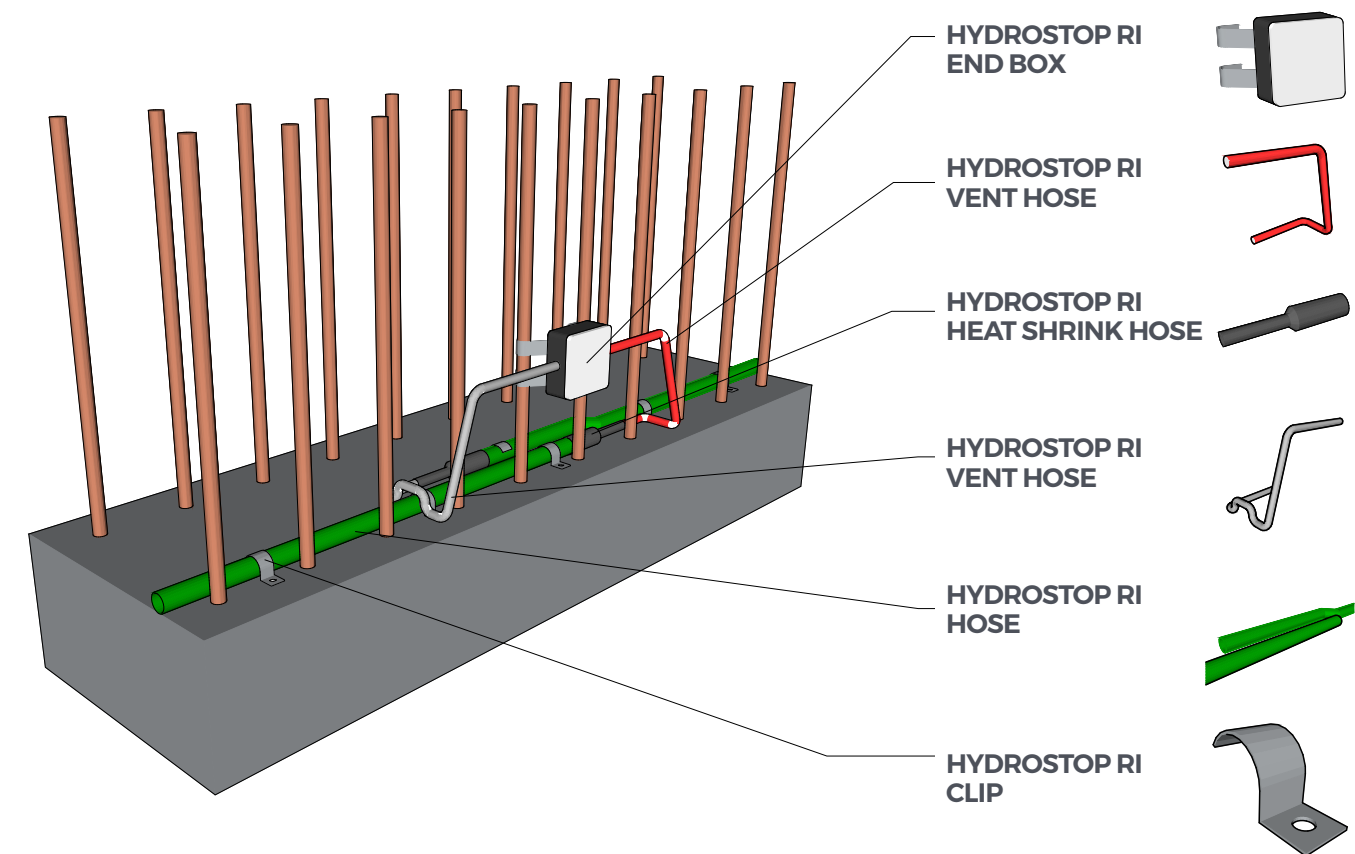

▲ Place a length of hot-shrinking hose (black) over the centre of the joint ensuring a good covering of both the red (or white) hose and the green hose and use a hot-air gun to tightly seal the hot-shrink hose. The overlaps of the green hose should be approximately 10cm and set apart by a gap of 2cm to 5cm. The connection between the ventilation and the injection hoses and the RI hose must be completely embedded within the concrete when cast.

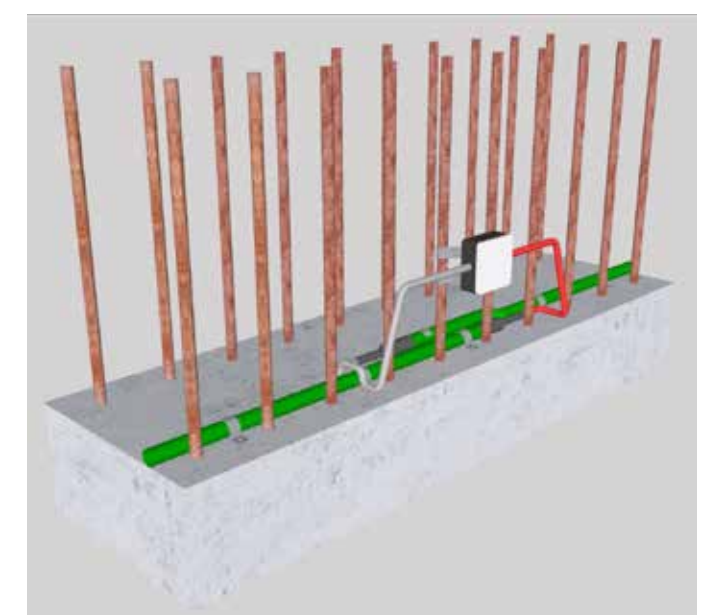

▲ The injection pipe (red) and the ventilation pipe (white) should be secured tightly to the reinforcement and secured tightly in the end box using tying-wire to ensure they do not move during concrete placement or the injection process.



HYDROSTOP WS10 PIPE PENETRATION



SMOOTH PIPE
Apply Hydrostop WS10 directly to pipe using tying wire to secure. Overlap waterbar by 75mm side by side. Position to maintain a minimum of 75mm concrete cover.



RIBBED PIPE
Fill ribs with Hydrostop WSM. Apply Hydrostop WS10 to pipe using tying wire to secure. Overlap waterbar by 75mm side by side. Position to maintain a minimum of 75mm concrete cover.



The box out penetration is an oversized opening in as concrete wall or slab, to allow a smaller service pipe or duct to pass through.

Using an applicator gun, apply Hydrostop WSM (Hydrophillic mastic sealant) directly onto the concrete surface around the outside of the void.

Press Hydrostop WS10 (hydrophillic rubber waterbar) firmly onto the Hydrostop WSM ensure continuous contact and adhesion to the concrete face.

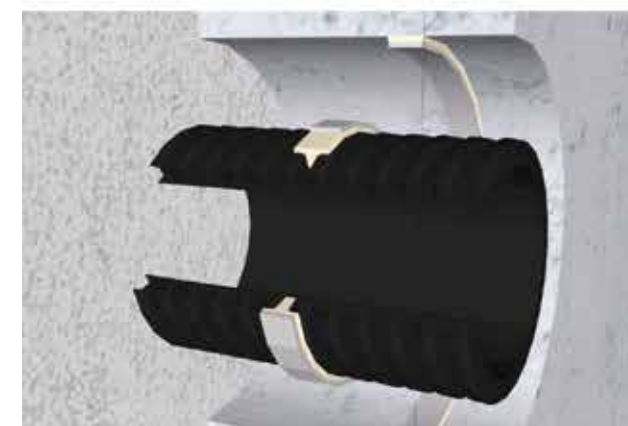

Wrap Hydrostop WS10 waterbar around the outside of the pipe or duct where it passes through the penetration.
Smooth pipe: secure WS10 with tying wire
Ribbed pipe: Apply Hydrostop WSM adhesive, then fix WS10 onto it.

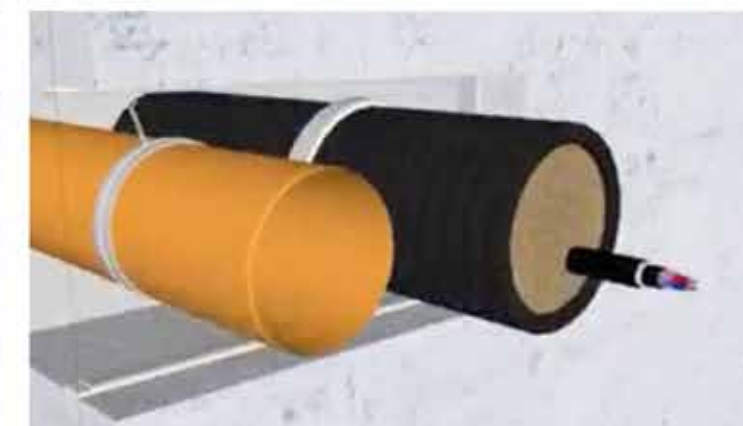

Regardless of the shape of the opening or the number of penetrations, the same principles apply.

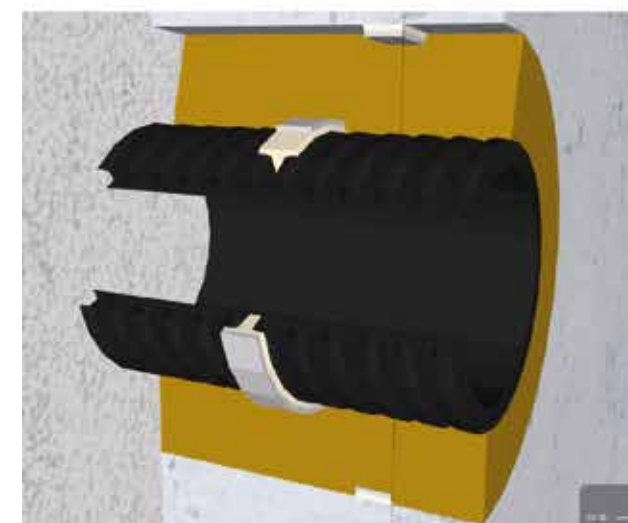

Prepare the concrete surface including removing laitants, loose debris plus oils and ensure a clean dry surface. Construct form work including a head box or tail outlet if needed.

Option 1: Maximum 50mm thick
Hydroprufe EP (waterproof epoxy grout)
Mix the resin and curing agent until homogeneous then blend in the filler component for two minutes without entraining air. Pour the

Option 2: Ideal for deep repairs or thick section grouting
Teknocem (high strength micro-concrete)
Mix the resin and curing agent until homogeneous then blend in the filler component for two minutes without entraining air.



APPLICATION STAGE 1:

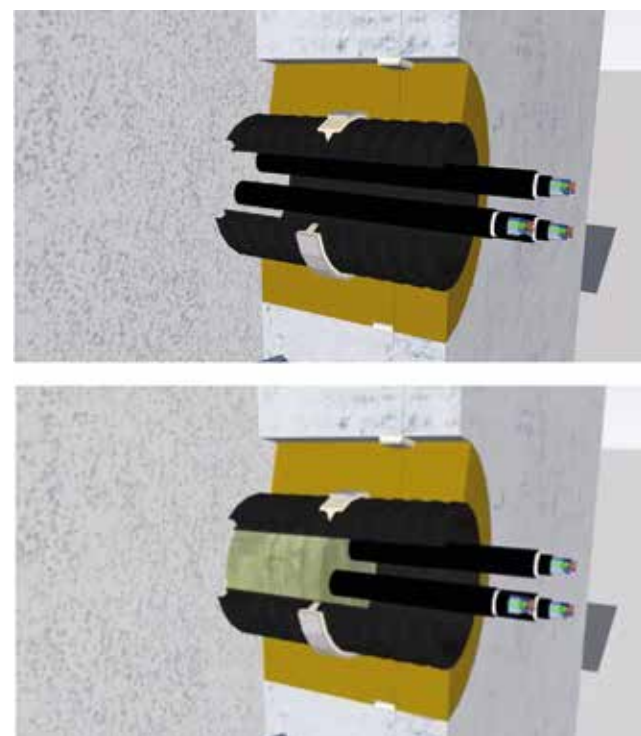

Prepare the void or cavity to be filled by removing all dust and loose particles with compressed air or water. If possible, insert a stopper at the rear of the void to be filled to contain the expansion of the HYDROPLUG filler component and densify the polyurethane foam. It is extremely important that if there are multiple cables passing through a single duct then the cable should be evenly spaced with a minimum of 20mm gap between cables to ensure the effective sealing around each cable.

Firstly, remove the metal can from the kit which is labelled RESIN and pour the contents of the small plastic ACCELERATOR bottle into the can and shake thoroughly. Once the RESIN is mixed then it should be poured into the plastic bag which contains the POLYESTER FIBRES and soak thoroughly by kneading the fibres until a homogenous consistency is achieved. Once the fibres are thoroughly wetted out then the fibre wad should be immersed into a bucket of water to activate the RESIN.

The fibre wad should then be removed from the bucket of water and pushed firmly into the rear of the void. The fibre wad should fill in between each cable, pressure should be exerted against the fibre wad until it has cured to ensure a dense closed cell foam is achieved.

APPLICATION STAGE 2:

The hardened HYDROPLUG filler component should be trimmed to 150mm from the face of the concrete. The HYDROPLUG putty component should then ideally be preheated in hot water whilst still in the plastic packaging to make the putty more workable. The putty should then be placed by hand ensuring it is well compacted between each cable. The HYDROPLUG putty should be built up to 50mm from the face of the concrete.

The HYDROPLUG mortar component should be mixed with 700ml of clean water to produce a pliable mortar. The mortar should then be placed to fill the remaining 50mm of the void, once again ensuring thorough compaction between each cable. It should then be finished using a trowel or putty knife to achieve a good finish.

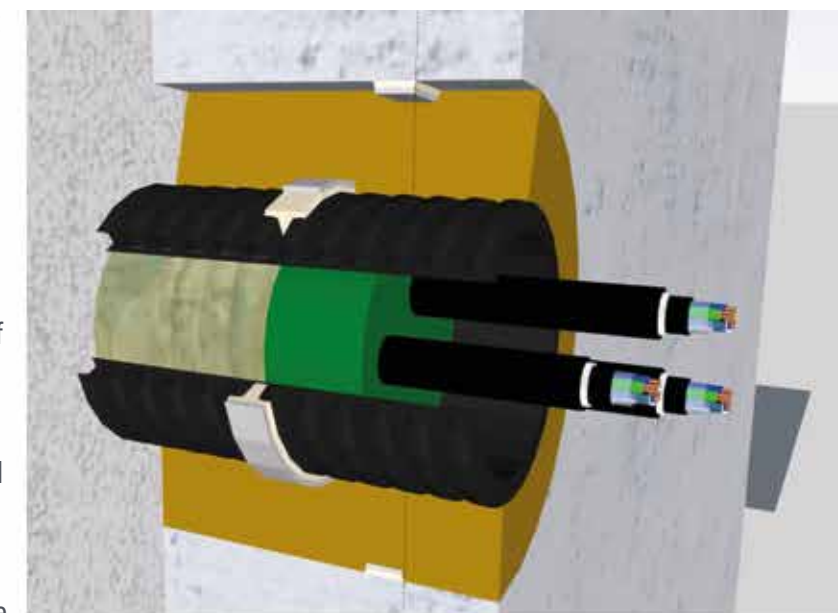

APPLICATION STAGE 3:



The HYDROPLUG mortar component should be mixed with 700ml of clean water to produce a pliable mortar. The mortar should then be placed to fill the remaining 50mm of the void, once again ensuring thorough compaction between each cable. It should then be finished using a trowel or putty knife to achieve a good finish.

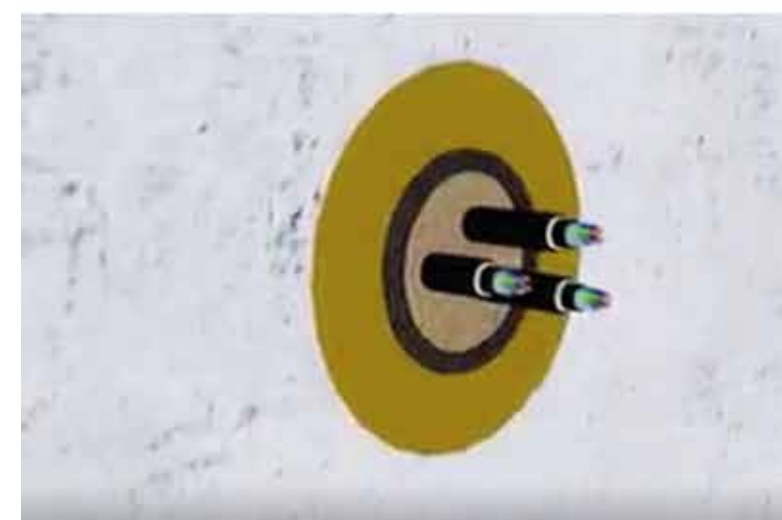

HYDROPLUG COVERAGE GUIDE

PACK SIZE
 3X FILLER @ 30G
 3X RESIN @ 450G
 3X ACCELERATOR 23G
 3X PUTTY @ 2KG
 1X MORTAR @ 5KG

PACK COVERAGE
 UP TO 8 LINEAR METRES
 25 X 3MM BEAD

1 PACK WILL BE SUFFICIENT TO SEAL APPROXIMATELY 3 X100MM DIAMETER PENETRATIONS THROUGH A 300MM THICK WALL.

PROTECTING
COMPLEX
STRUCTURES



MAXIPRUFES PLUS

Product Glossary

- Preparation
- Hydroseal FX mixing
- Hydroseal FX application
- Maxiprufe Plus application
- Twinseal Compound GR application
- Capping beam Illustration & sequencing
- Maxiprufe Plus fixing
- Penetration detailing
- Piled wall detailing

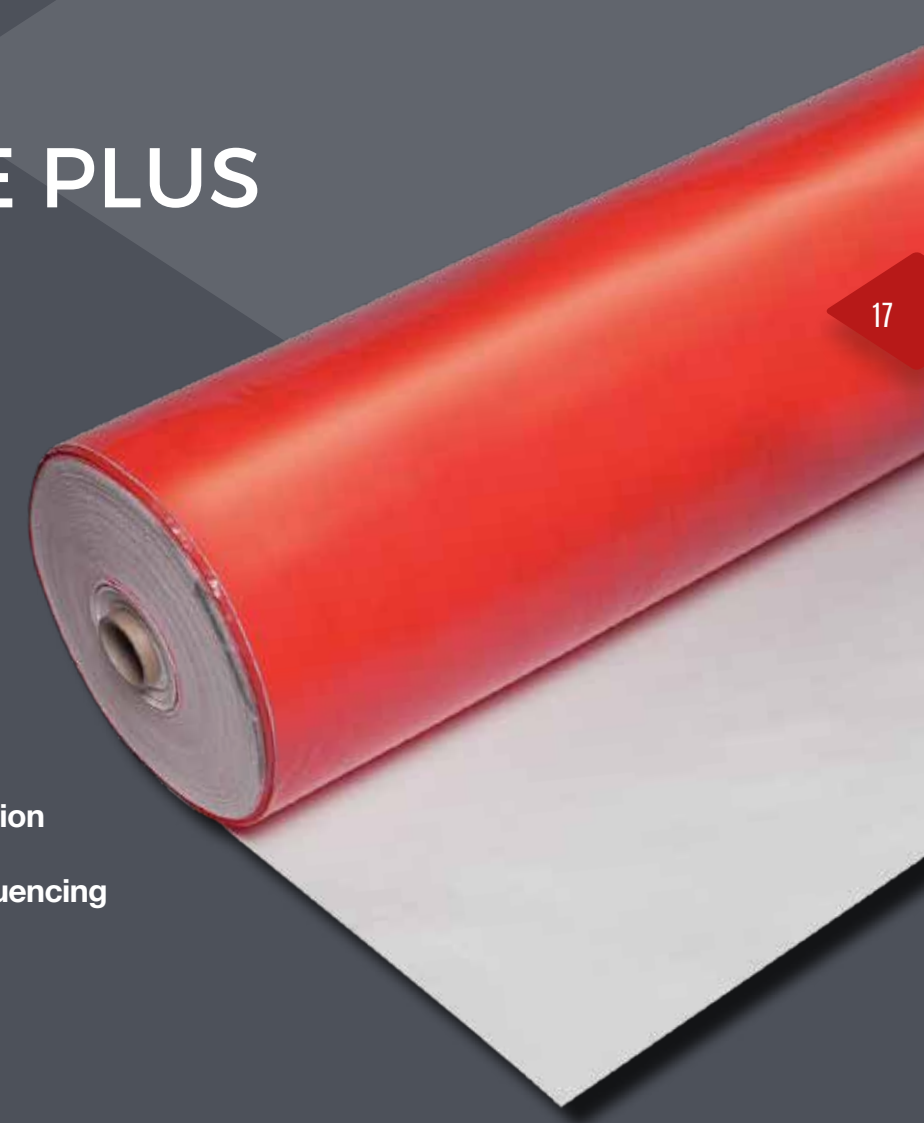



PILE HEAD/PILE CAP PREPARATION



Substrates should be thoroughly jetwashed to remove loose material.
Use airline to remove standing water.



MIXING THE HYDROSEAL FX



Mix one full bag of powder with one full container of liquid – no part mixing.



Pour all the liquid component into the bucket and then add the powder slowly to ensure continuous mixing.



Thoroughly mix for five minutes using mixing paddle.

APPLICATION



Ensure concrete is damp with no standing water and apply as a single 2mm thick coating. Ensure Hydroseal FX is applied to the sides of the pile head to meet the blinding level.

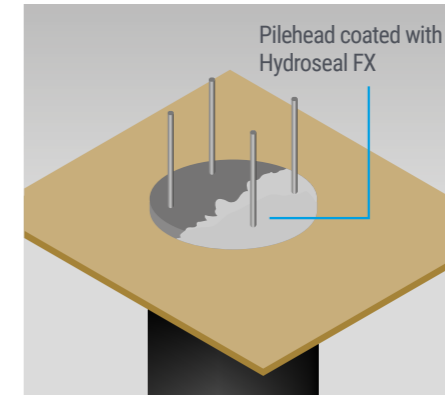

HYDROSEAL FX COVERAGE GUIDE	
PRODUCT SIZE (2 PART) 30KG COVERAGE UP TO 6.5 M ²	
450MM PILE HEADS	600MM PILE HEADS
x17	x11



Cut membrane tightly to the pilehead.

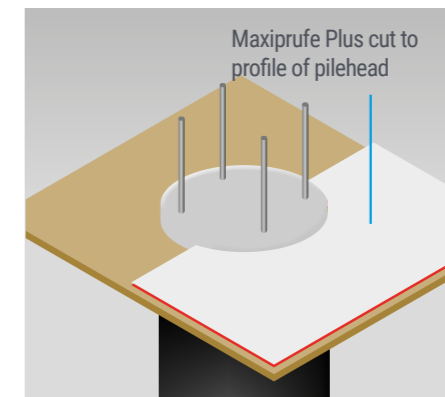

Add curing agent to the base component and mix for 3 minutes. Brush apply the Twinseal GR as a 3mm x 100mm application.

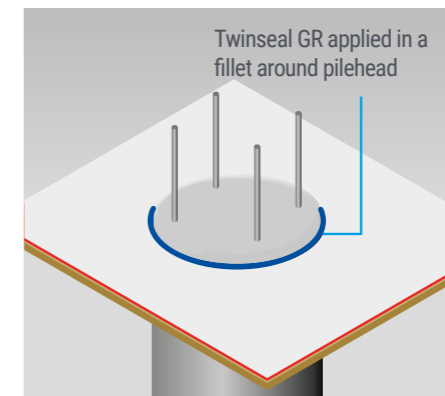

TWINSEAL GR COVERAGE GUIDE	
PRODUCT SIZE (2 PART) 5KG COVERAGE UP TO 9.5 LINEAR METRES	
450MM PILE HEADS	600MM PILE HEADS
x6	x5

TYPICAL CAPPING BEAM ILLUSTRATIONS & SEQUENCING

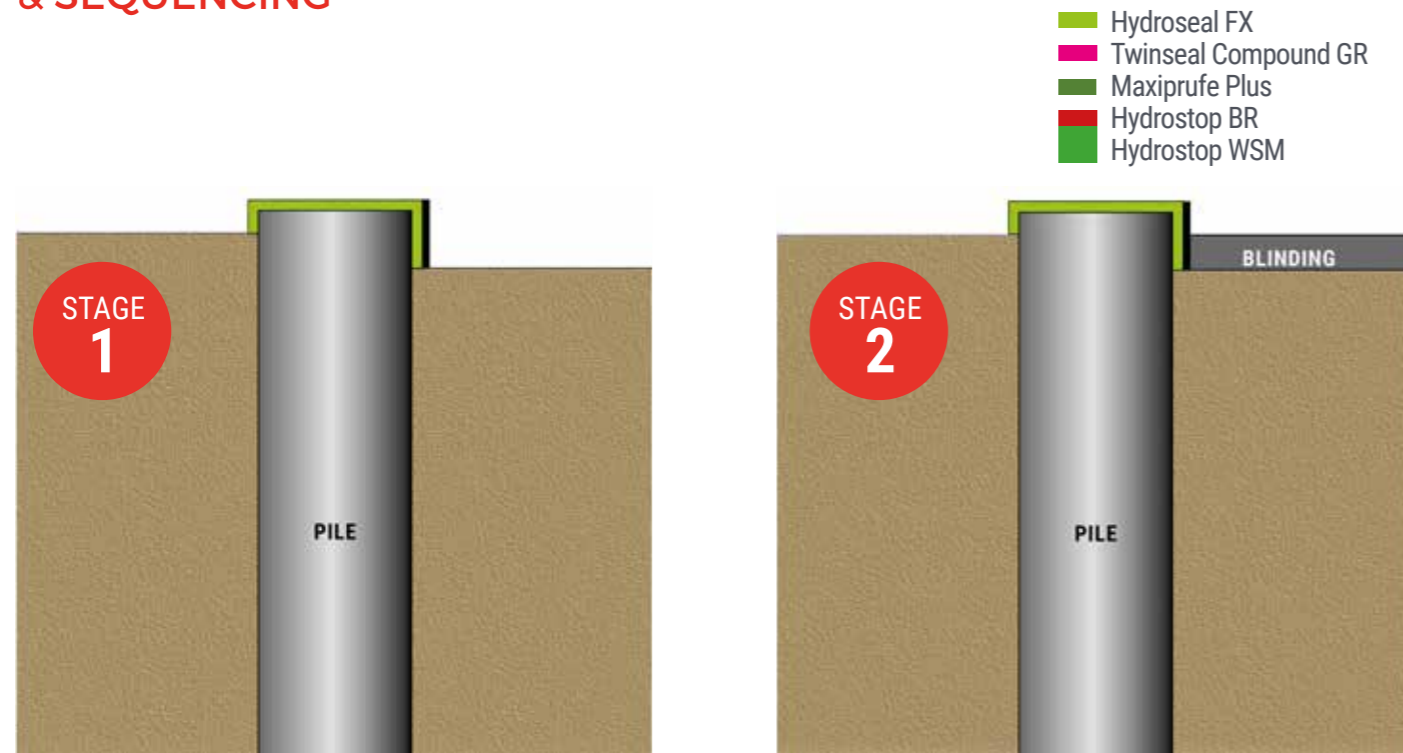

STAGE 1
Coat pileheads with Hydroseal FX and place Correx Board against the basement side of piles.

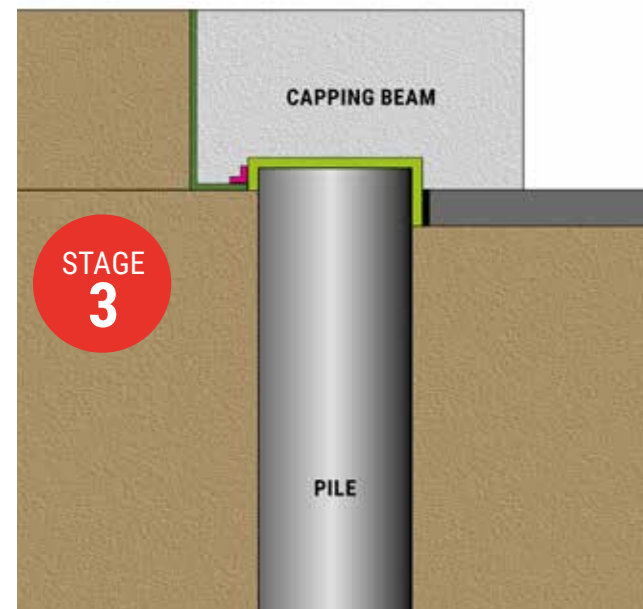

STAGE 3
Install membrane to the outside of the pilehead and capping beam and seal the membrane to the pile head with Twinseal Compound GR.

STAGE 2
Cast blinding against Correx Board.

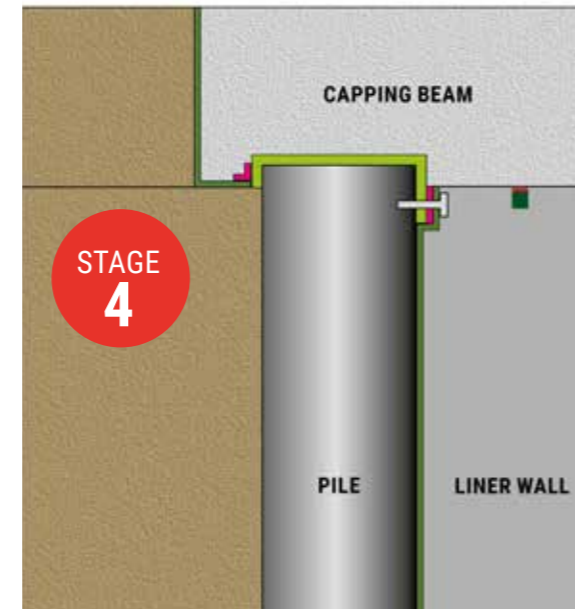

STAGE 4
When capping beam is cast, and basement excavation is taking place, remove the Correx board exposing the Hydroseal FX ready to connect the membrane.

FIXINGS & APPLICATION



Overlap membrane by 100mm and fix using metal washer fixings at 500mm centres. In vertical applications, the membrane fixed in the higher position, should be lapped over the top of the membrane fixed in the lower position by 150mm to prevent concrete penetrating between laps.

MAXIPRUF PLUS - PENETRATION SEALING

With a ribbed pipe, Hydrostop WSM should be applied before Hydrostop WS10 to fill the ribs. Ensure Hydrostop WS10 is lapped side by side by 50mm and secure with tying wire. Smooth pipes don't require Hydrostop WSM and should be held in place with tying wire. Twinseal Compound GR should be applied as a 3mm thick and 100mm wide 'band', consisting of a minimum 50mm lap onto the face of the membrane and a minimum 50mm lap around the pipe.

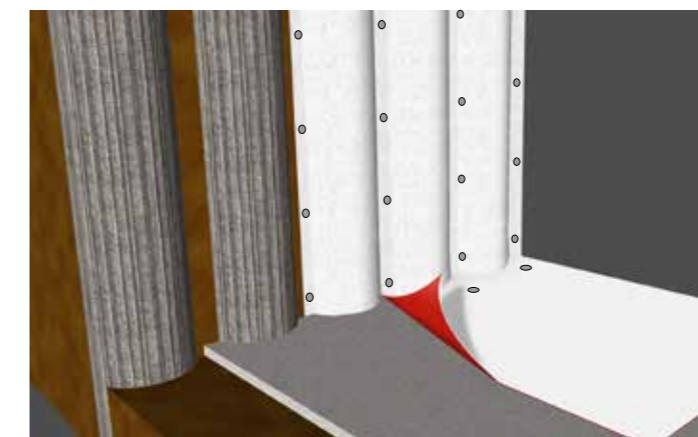
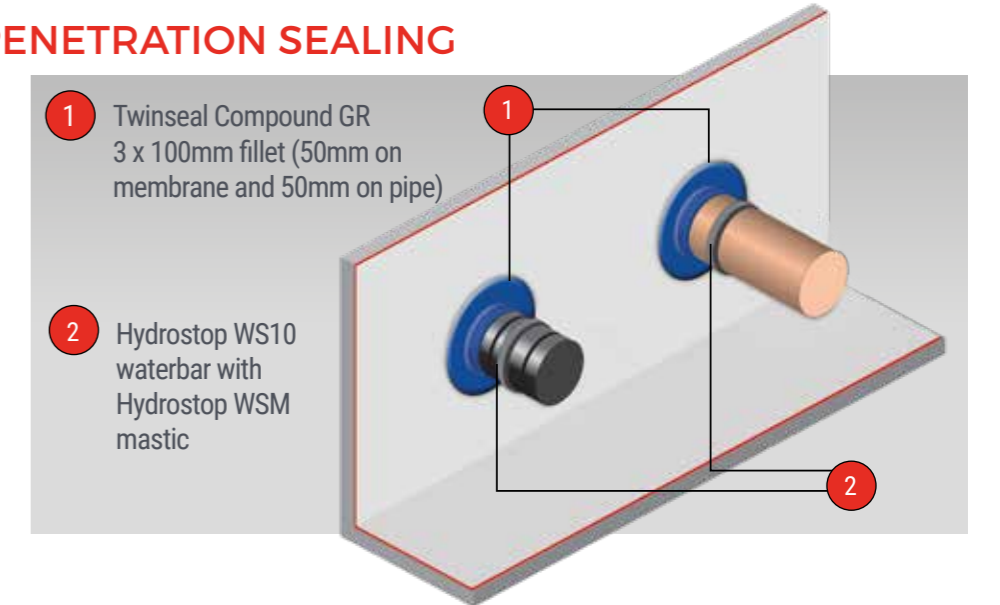

Trim horizontal membrane to blinding and fix tightly into the contours of the piles. Also fix wall membrane tightly into the contours of the piles with Metal Washer Fixings.

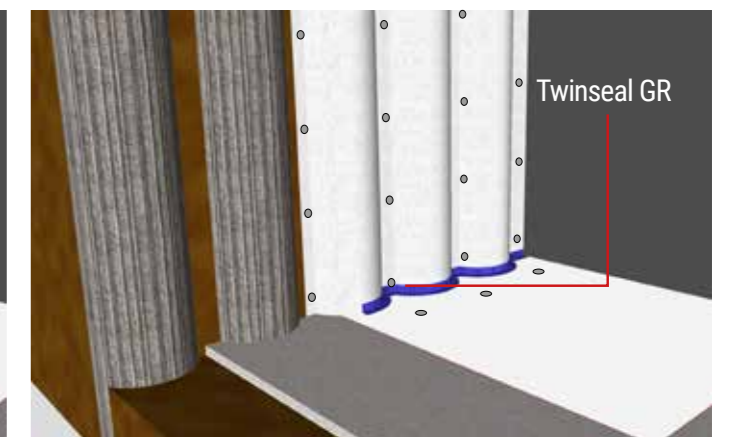

Apply 3mm thick x 100mm wide strip of Twinseal Compound GR along base of wall, sealing between slab and wall membrane.

REMEDICATION OF MEMBRANE
(ONLY WHEN REQUIRED)

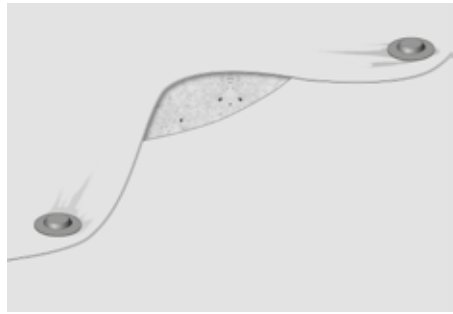

Due to the MS Polymer Technology, the membrane will show a degree of movement during times of heat exposure.

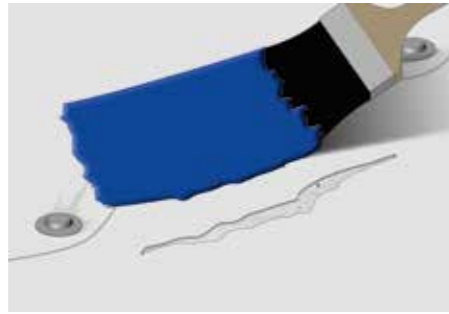

For damaged areas less than 100mm (ie shrinkage or tears), the membrane can be repaired by applying a layer of Twinseal Compound GR.

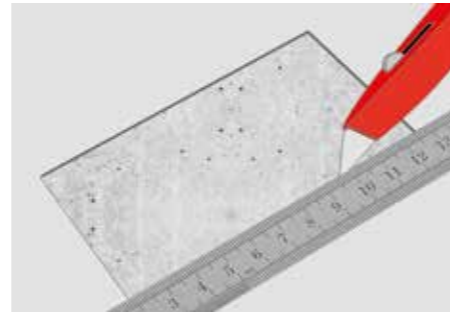

For damaged areas exceeding 100mm, this can be remediated, by cutting back the area of membrane to reveal a 'cut away area' with straight edges.

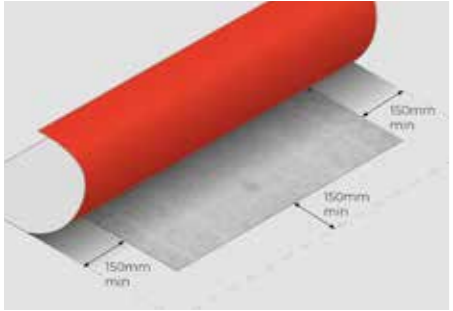

Place a new section of membrane cut to a shape (size exceeding the repair area by 150mm all round) and lay over the top of the damaged area.

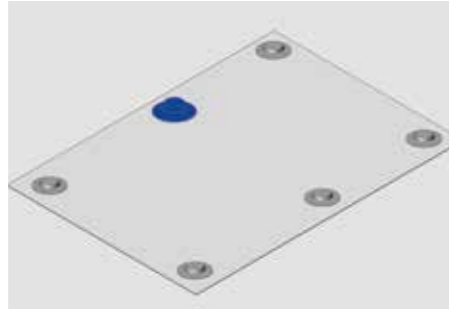

Washer fixings should be used for fixing any remedial membrane pieces into the substrate and these should be nailed through the joints of the membrane where possible and the head of the fixing must be sealed over using Twinseal Compound GR.

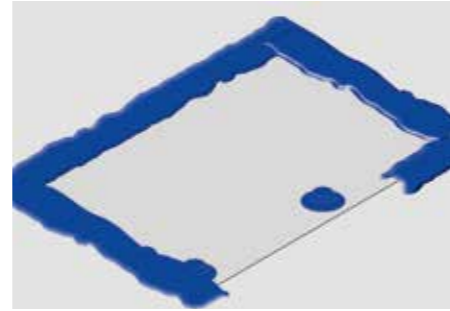

In some cases it may be required to seal the edges of the new piece of membrane with Twinseal Compound GR if fixings can't be applied with ease.

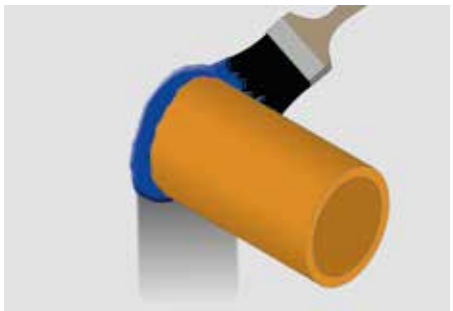

Any penetrations (i.e. drainage pipes or reinforcing anchors into piles) should be sealed with Twinseal Compound GR. In instances where a layer of Twinseal GR cracks, reapply another layer of Twinseal GR on top.

COMBISEAL HD COMBISEAL PLUS

Product Glossary

- Pile head/Pile cap preparation
- Hydroprufe LG mixing
- Hydroprufe LG application
- CombiSeal application
- Twinseal Compound GR mixing
- Twinseal Compound GR application
- Capping beam Illustration & sequencing
- CombiSeal jointing
- CombiSeal fixing
- Protection Board 600 detailing
- CombiSeal detailing
- Penetration detailing

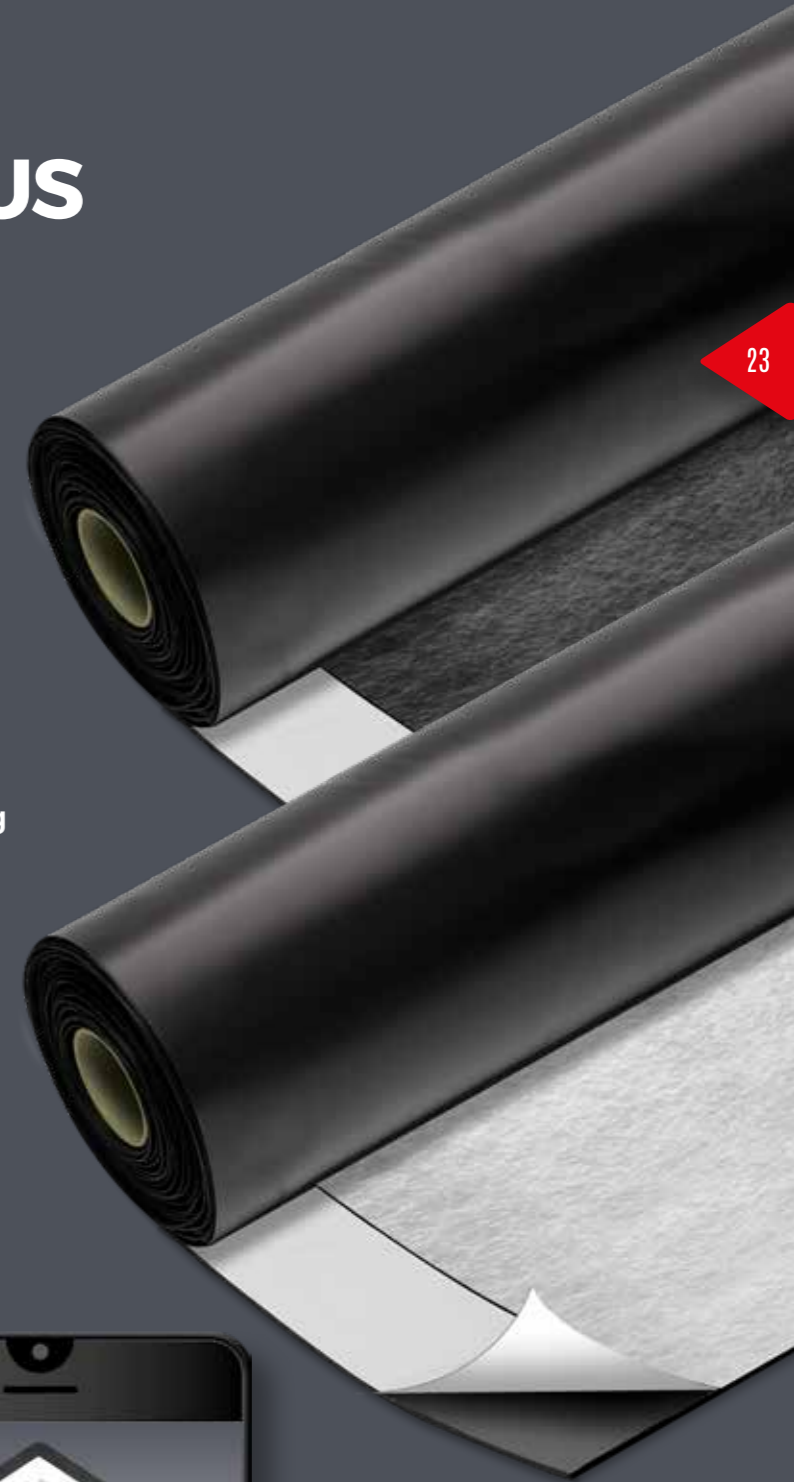



PILE HEAD/PILE CAP PREPARATION



Substrates should be thoroughly jetwashed to remove loose material.
Use airline to remove standing water.



HYDROPRUFE LG MIXING



Hydroprufe LG is supplied with two components: base & curing agent.



Pour the curing agent into the base component and mix for 2-3 minutes using a drill and mixing paddle.

HYDROPRUFE LG COVERAGE GUIDE	
PRODUCT SIZE (2 PART) 5LTR	
COVERAGE UP TO 4.5 M ²	
450MM PILE HEADS	600MM PILE HEADS
x12	x8

APPLICATION

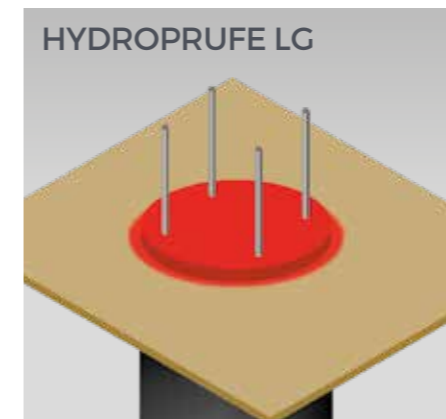

Apply Hydroprufe LG at a minimum thickness of 1mm and ensure fully coated down the sides of the piles to blinding level.

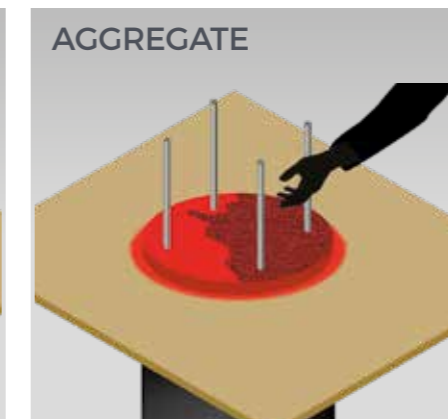

Apply Quartz Aggregate to wet coating at 0.5kg / m². Allow to dry prior to detailing membrane. Typically overnight.

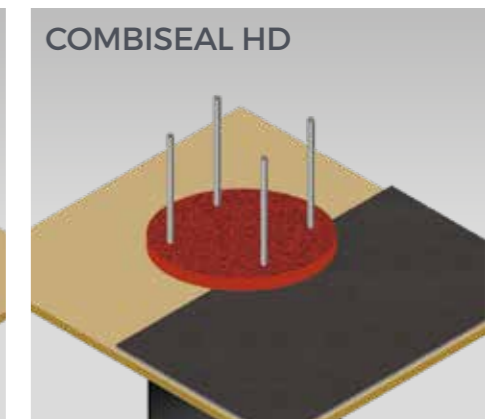

Cut membrane tightly to the pile head.

TWINSEAL COMPOUND GR MIXING



Twinseal Compound GR is supplied in two components: base & curing agent.



Add curing agent to the base and mix for 2 - 3 minutes with mixing paddle.

TWINSEAL GR COVERAGE GUIDE	
PRODUCT SIZE (2 PART) 5KG	
COVERAGE UP TO 9.5 LINEAR METRES	
450MM PILEHEADS	600MM PILEHEADS
x6	x5

TWINSEAL COMPOUND GR APPLICATION

CombiSeal Plus is recommended for vertical application onto piled wall. CombiSeal HD can be used on vertical application if the piled wall is faced up with spray applied concrete or spray foam.

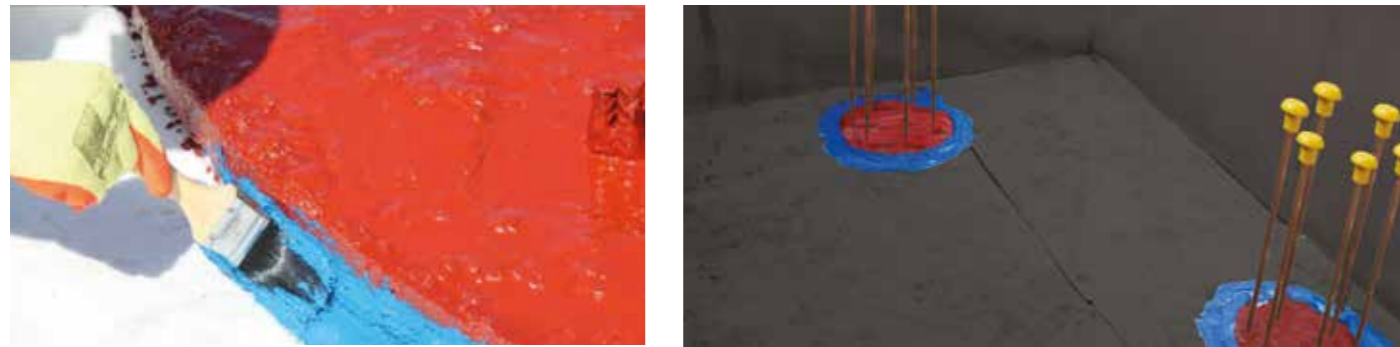

Brush apply the Twinseal Compound GR as a 3mm thick x 100mm wide strip.

TYPICAL CAPPING BEAM ILLUSTRATIONS & SEQUENCING

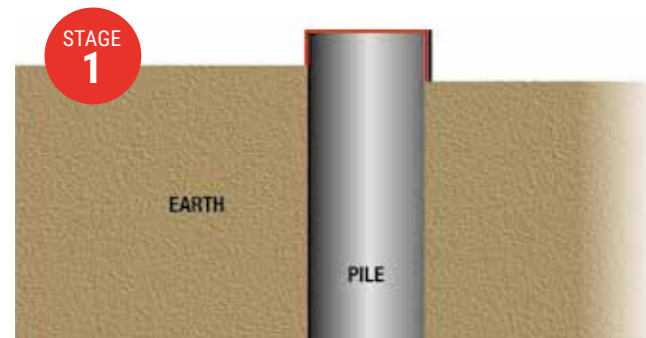

Coat pile heads with Hydroprufe LG and place Correx Board against the basement side of piles.

- CombiSeal Plus
- Hydroprufe LG
- Hydroprufe 8000
- Protection Board
- ▲ Teknocem HBR Fillet
- Twinseal GR
- Termination Bar
- Hydrostop BR on Hydrostop WSM

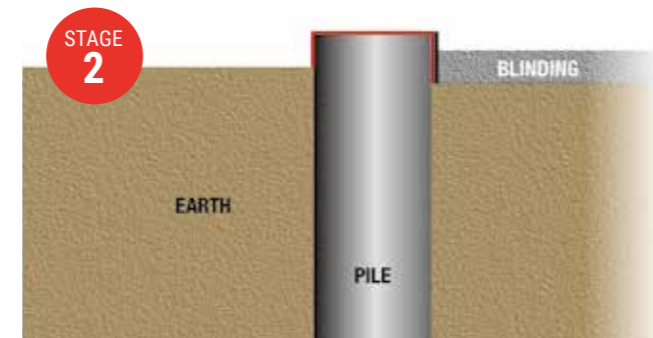

Cast blinding against Correx Board.

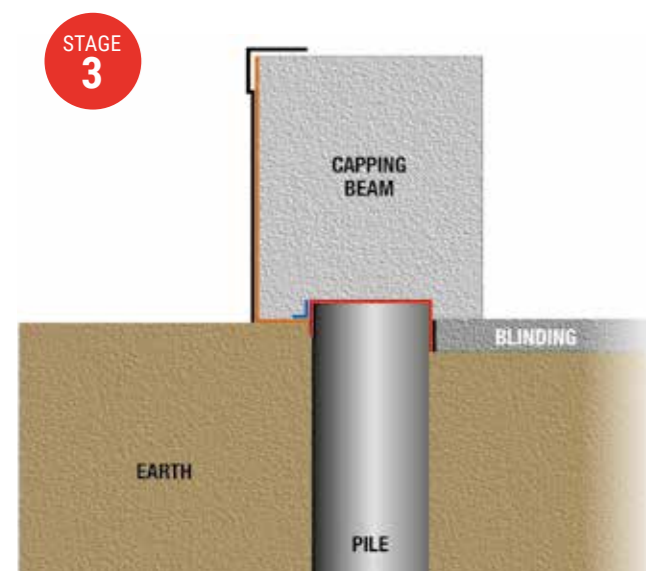

Install membrane to the outside of the pilehead and capping beam and seal the membrane to the pile head with Twinseal Compound GR. Install Protection Board 600 to outside of capping beam, prior to backfilling.

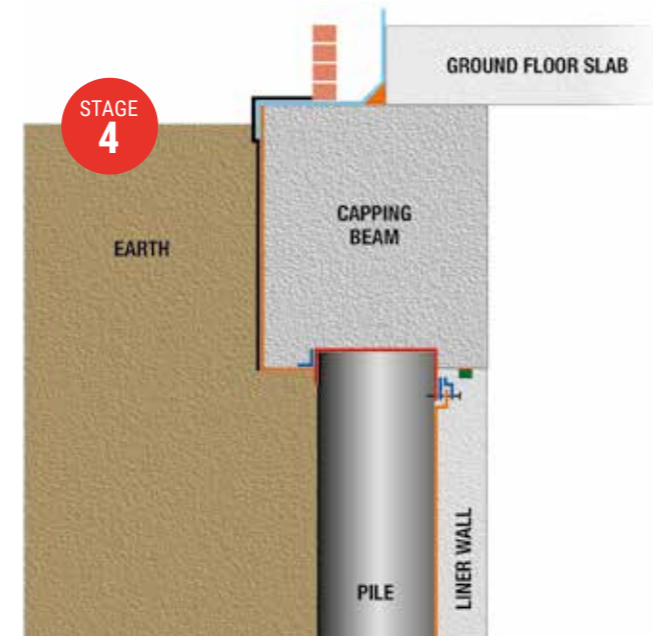

When capping beam is cast, and basement excavation is taking place, remove the Correx board exposing the Hydroprufe LG ready to connect the membrane.

COMBISEAL MEMBRANES - JOINTING

These illustrations with white fleece show CombiSeal Plus but the same principle applies for CombiSeal HD.



Remove white release paper from selvedge tape and butt joint the membrane ensuring a consistent seal along the lap.



For detailing use CombiSeal Tape applied to the black side of the membrane ensuring a lap of 150mm.



Use a seam roller to compress the taped joint.

COMBISEAL HD - FIXING

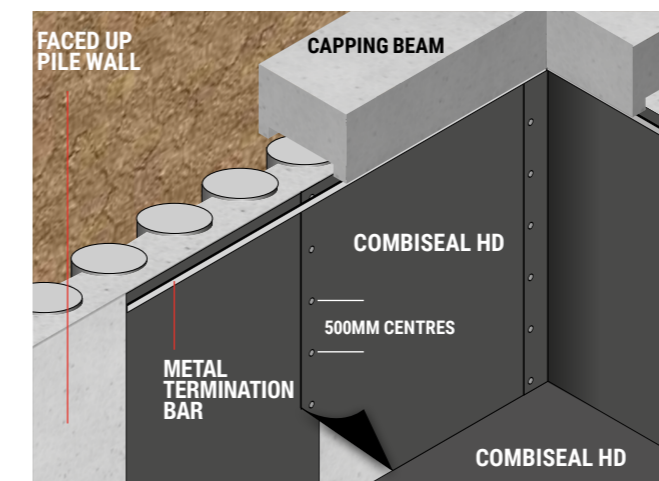

CombiSeal HD only requires fixing in vertical applications, at 500mm centres along the taped joint and fixed across the top with retaining strip. Please note CombiSeal HD can only be installed vertically when the piles have been faced up or where there is an even surface to fix to.

COMBISEAL PLUS - FIXING

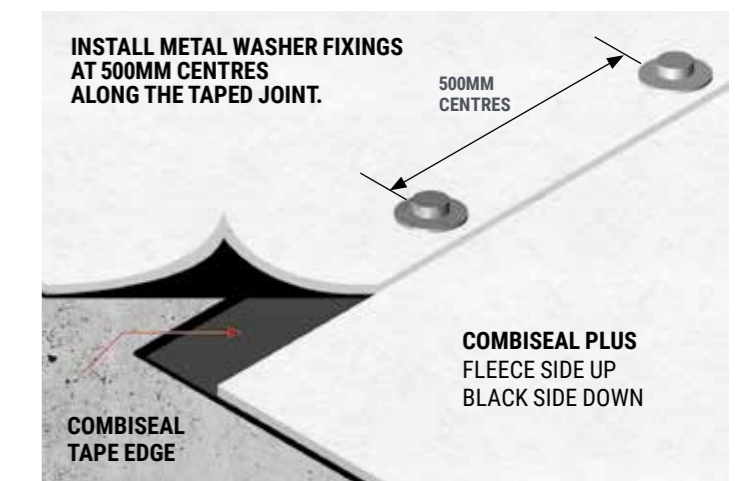

Lap membrane by 150mm and fix at 500mm centres. In both horizontal and vertical applications, the higher membrane should be lapped over the lower membrane by 150mm.



Where nails aren't fixed through the tape, overcoat the penetration with Twinseal Compound GR. These illustrations show CombiSeal Plus but the same principle applies for CombiSeal HD.

COMBISEAL MEMBRANE - PROTECTION



PROTECTION BOARD 600

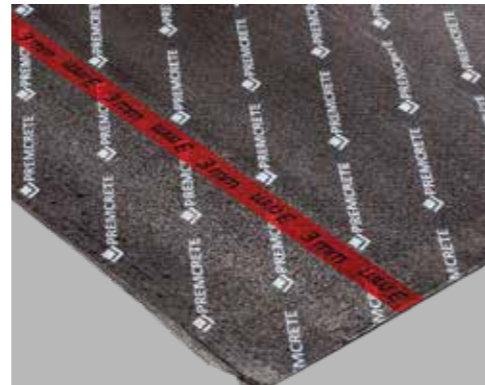

When backfilling against CombiSeal membranes, Protection Board 600 should be used to protect membrane from puncture.

COMBISEAL HD - FIXING TO PILE CAP

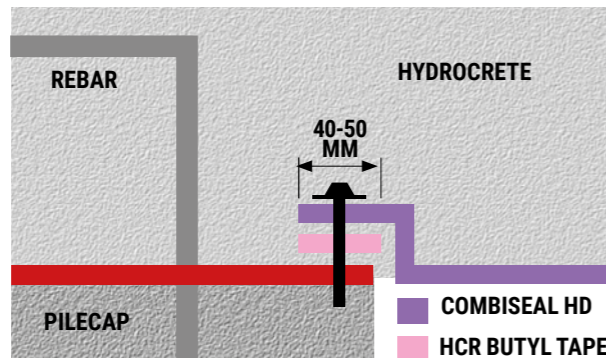

Aim to achieve a smooth trowelled surface to the perimeter of pile caps and beams, for applying HCR Butyl Tape to, once the Hydroprufe LG has dried.

Section through pilecap showing CombiSeal HD membrane application.



Metal Washer Fixings installed at 500mm centres around perimeter.

COMBISEAL MEMBRANES - PENETRATION SEALING

With a ribbed pipe, Hydrostop WSM should be applied before Hydrostop WS10 to fill the ribs.

Ensure Hydrostop WS10 is lapped side by side by 50mm and secure with tying wire. Smooth pipes don't require Hydrostop WSM and should be held in place with tying wire.

Twinseal Compound GR should be applied as a 3mm thick and 100mm wide 'band', consisting of a minimum 50mm lap onto the face of the membrane and a minimum 50mm lap around the pipe.

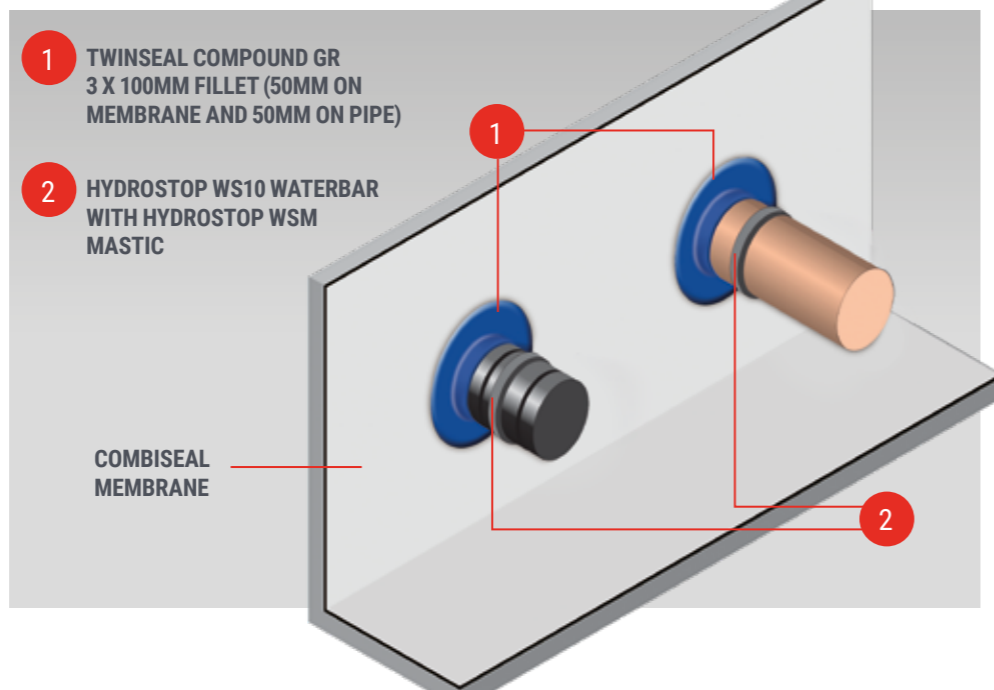

COMBISEAL HD & COMBISEAL PLUS - DETAILING TO PILED WALL

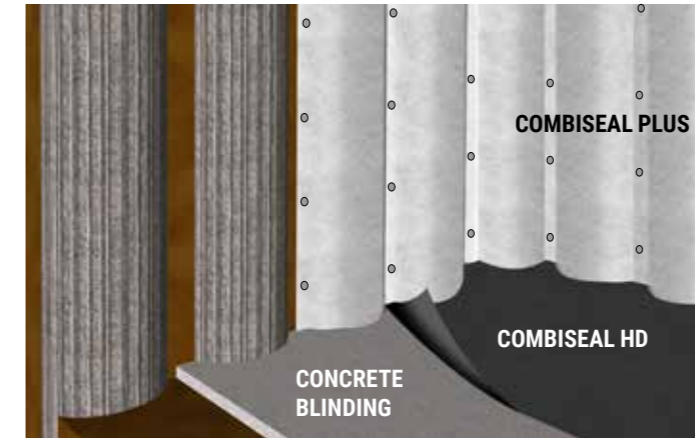

Trim CombiSeal HD Membrane to contours of the piles with tolerance of 20mm.

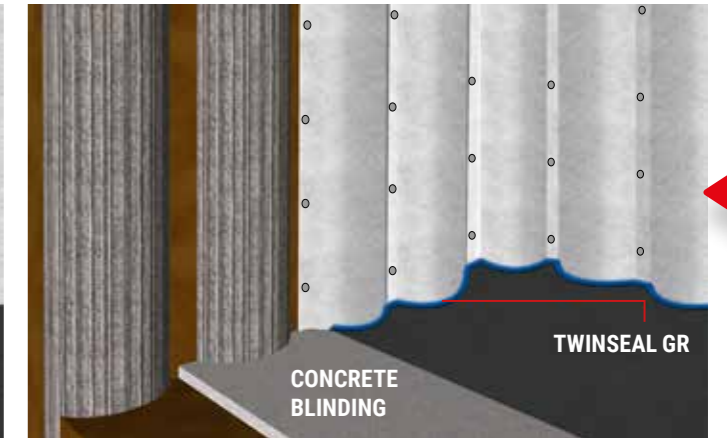

Apply 3mm x 100mm fillet of Twinseal GR along base of wall, sealing between CombiSeal HD on the floor and CombiSeal Plus on the wall.

FORMING CORNER DETAILS

These illustrations show CombiSeal Plus but the same principle applies for CombiSeal HD.

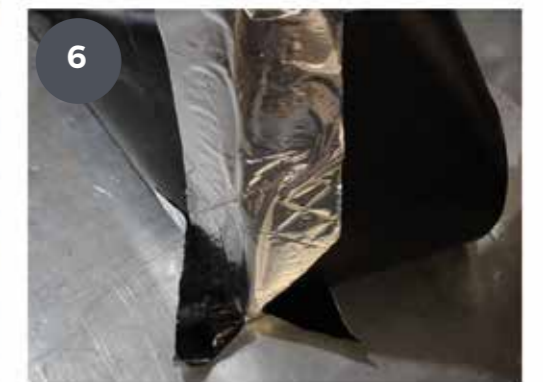

COMBISEAL MEMBRANES - REPAIR

These illustrations show Combiseal Plus but the same principle applies for Combiseal HD.

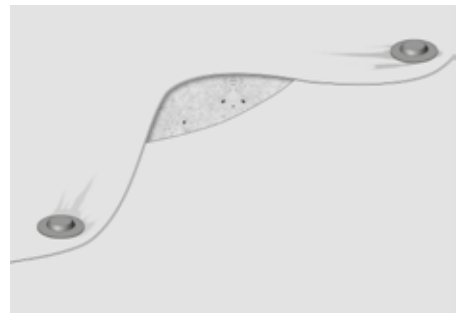

If the membrane has been subject to damage or shrinkage, this will require repair.

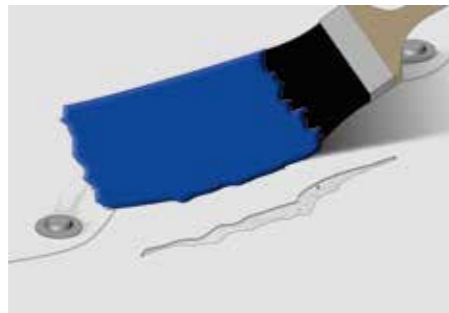

For damaged areas less than 100mm (ie shrinkage or tears), the membrane can be repaired by applying a layer of Twinseal Compound GR.

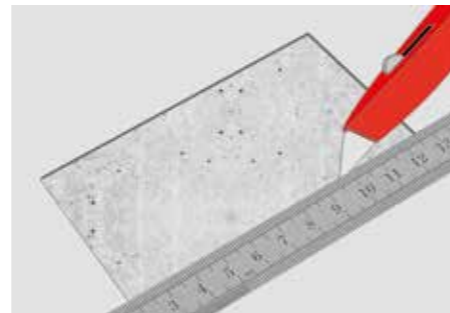

For damaged areas exceeding 100mm, this can be remediated, by cutting back the area of membrane to reveal a 'cut away area' with straight edges.

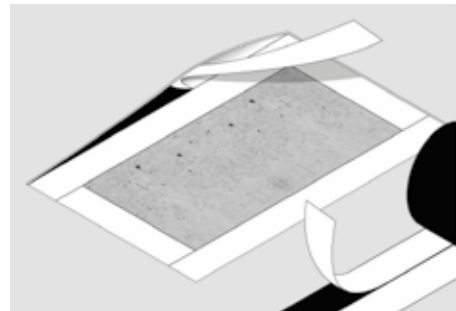

The laps must be re-taped by applying Combiseal Tape to the black underside of the membrane around the perimeter of the cut away area, leaving half the width of the tape (75mm) exposed.

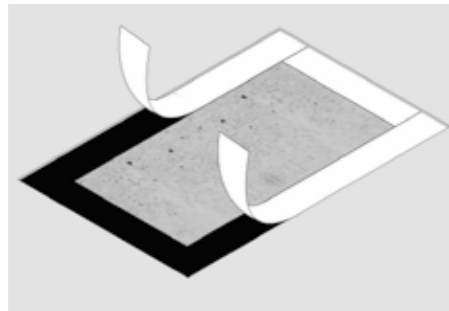

Remove the release paper from the exposed tape revealing the black adhesive side of the Combiseal Tape.

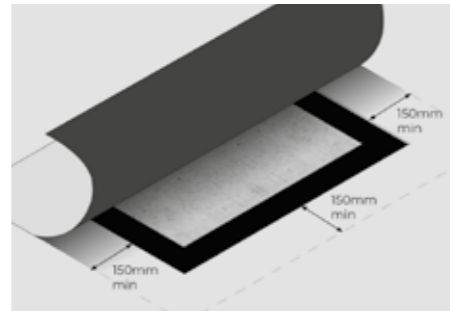

Place a new section of membrane cut to a shape (size exceeding the repair area by 150mm all round) and lay over the top of the damaged area.

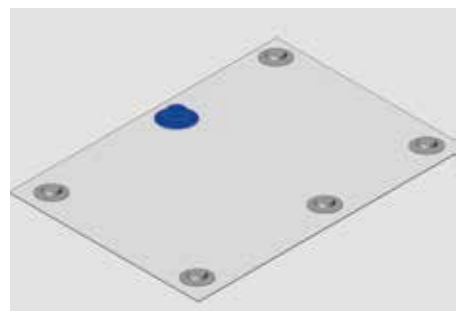

Metal Washer Fixings should be used for fixing any remedial membrane pieces into the substrate and these should be nailed through the joints of the membrane where possible and the head of the fixing must be sealed over using Twinseal Compound GR.

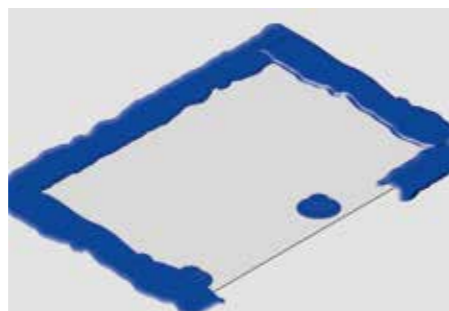

In some cases it may be required to seal the edges of the new piece of membrane with Twinseal Compound GR if fixings can't be applied with ease.

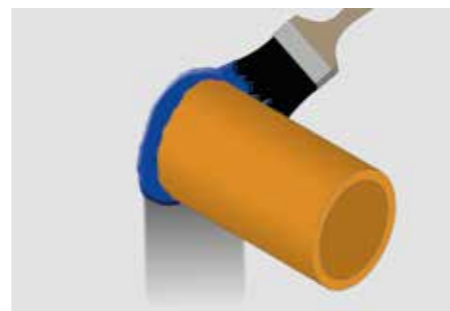

Any penetrations (i.e. drainage pipes or reinforcing anchors into piles) should be sealed with Twinseal Compound GR. In instances where a layer of Twinseal GR cracks, reapply another layer of Twinseal GR on top.

HYDROPRUFE 6000 & 9000

Product Glossary

- Pile head / Pile cap preparation
- Hydroprufe LG mixing
- Hydroprufe LG application
- Pile cap Membrane application
- Jointing membrane taping details
- Jointing membrane detailing
- Pipe penetrations
- Protecting membrane

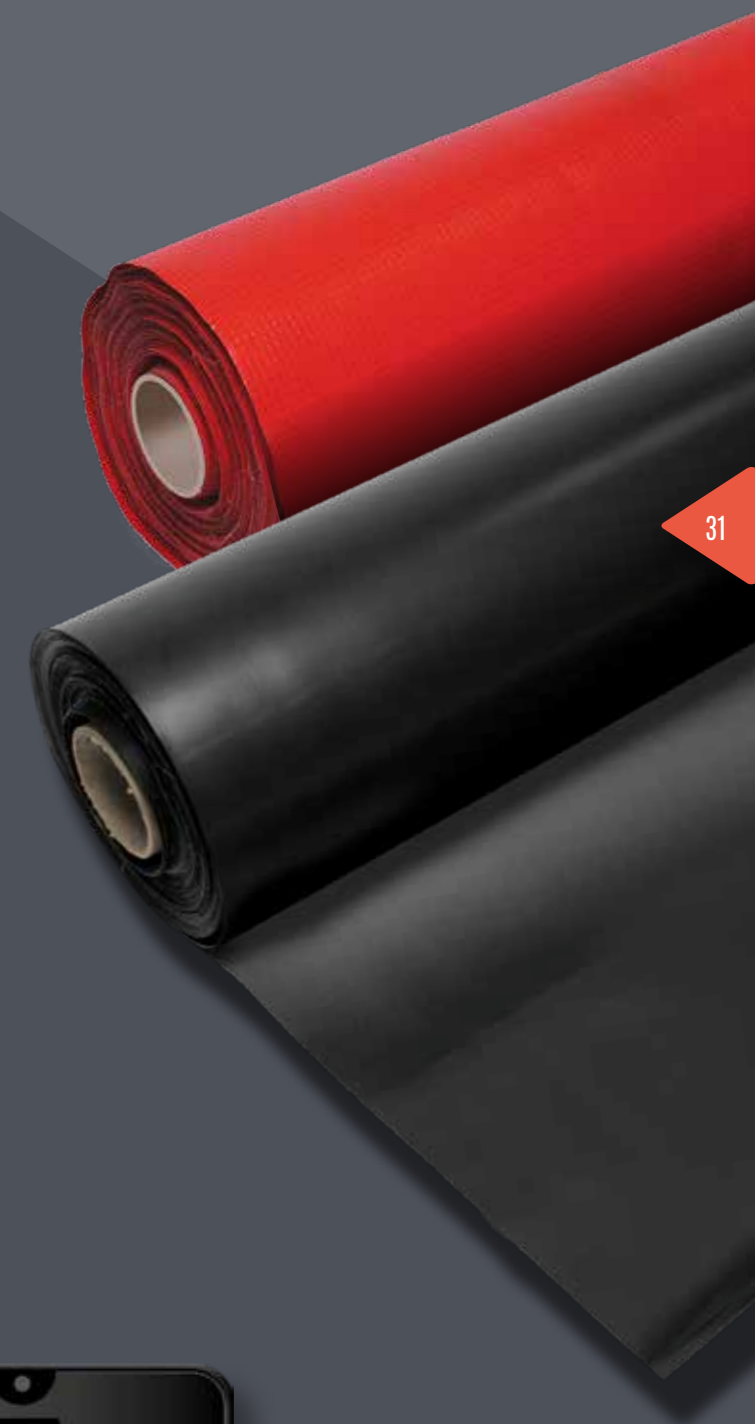

SCAN HERE TO VIEW OUR
HYDROPRUFE 6000
DATA SHEET AND
TRAINING VIDEO



SCAN HERE TO VIEW OUR
HYDROPRUFE 9000
DATA SHEET AND
TRAINING VIDEO





PILEHEAD/PILE CAP PREPARATION



Substrates should be thoroughly jetwashed to remove loose material.
Use airline to remove standing water.



HYDROPRUFE LG MIXING



Hydroprufe LG is supplied with two components: base & curing agent.



Pour the curing agent into the base component and mix for 2-3 minutes using a drill and mixing paddle.

HYDROPRUFE LG COVERAGE GUIDE

PRODUCT SIZE (2 PART)
5LTR
COVERAGE
UP TO 4.5M²

450MM
PILE HEADS

x12

600MM
PILE HEADS

x8

APPLICATION

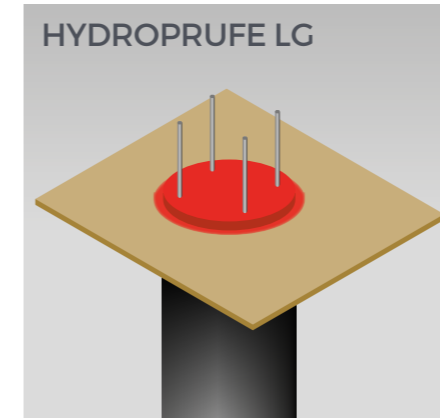

Apply Hydroprufe LG at a minimum thickness of 1m and ensure fully coated down the sides of the piles to blinding level.

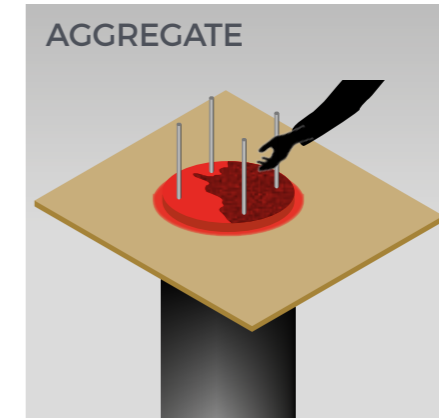

Apply Quartz Aggregate to wet coating at 0.5kg / m². Allow to dry prior to detailing membrane. Typically overnight.

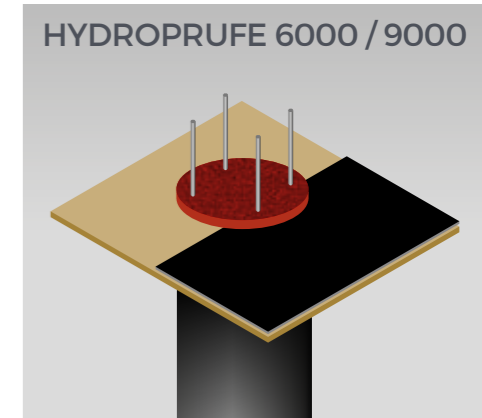

Cut membrane tightly to the pile head.

HYDROPRUFE 9000/6000 APPLICATION

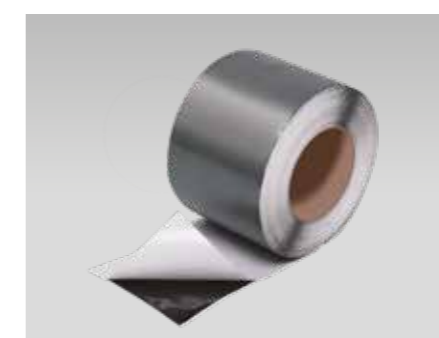
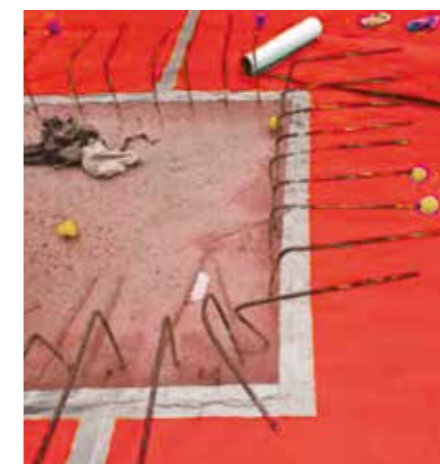

Cut membrane tightly to the pilehead/cap and seal using HCR Foil Girth Tape.

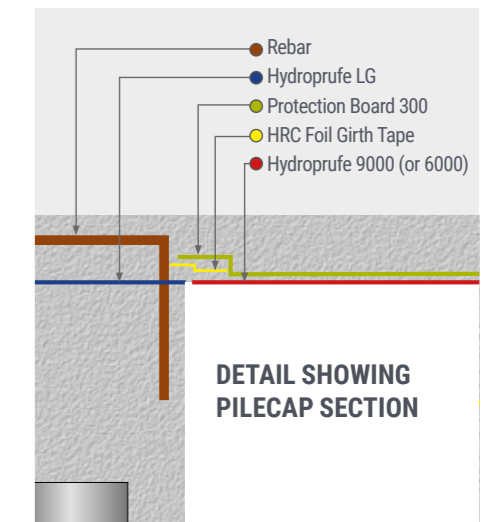

MEMBRANE JOINTING

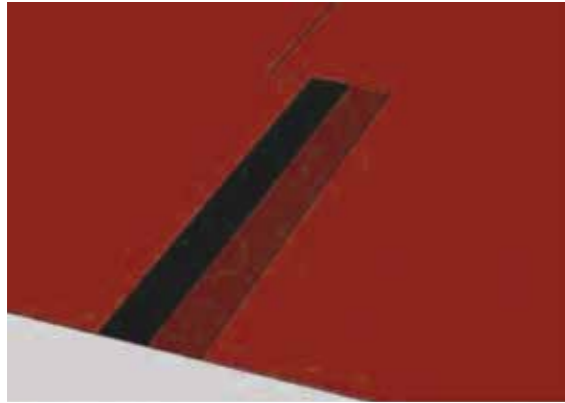

Minimum overlap between membrane should be 150mm.



Laps sealed using HCR Butyl Tape between lap and HCR Foil Girth Tape overlap.



MEMBRANE PENETRATIONS

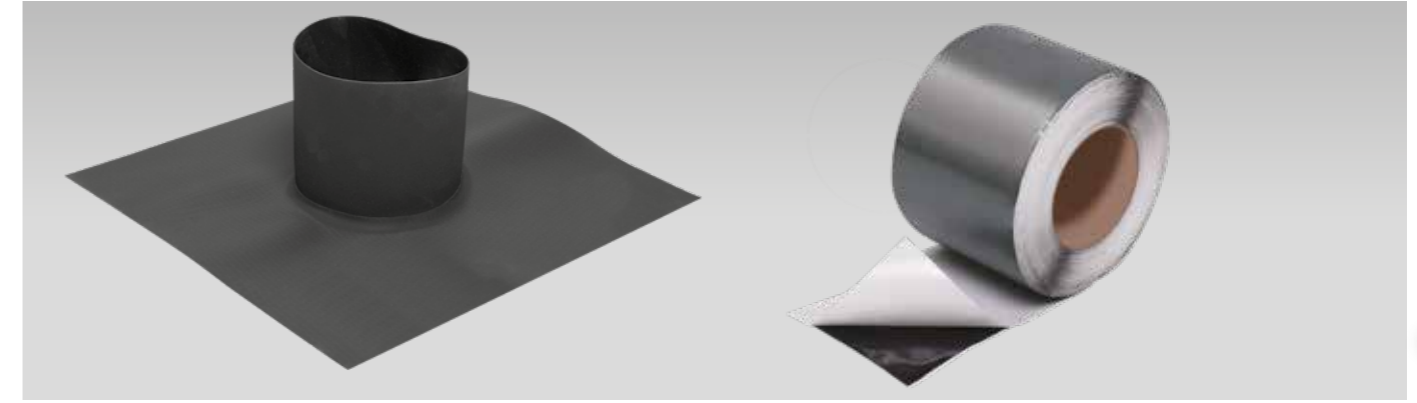

Seal using Hydroprufe Tophat to suit. Tape flanges to membrane using HRC Foil Girth Tape.

MEMBRANE DETAILING



Membrane prior to protection board installation.

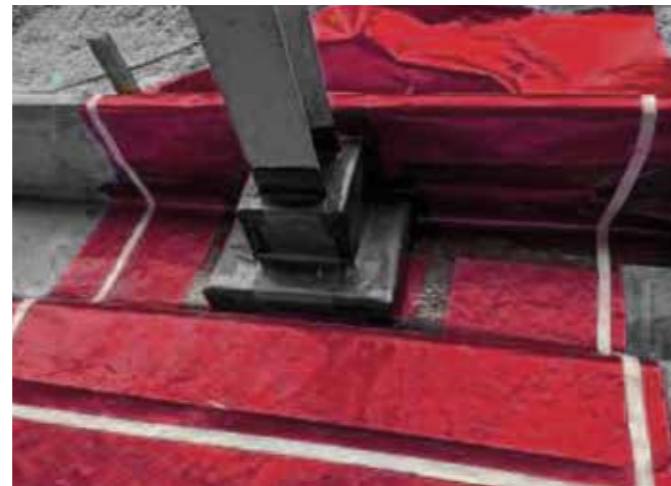

Care to be taken on areas with increased contours.

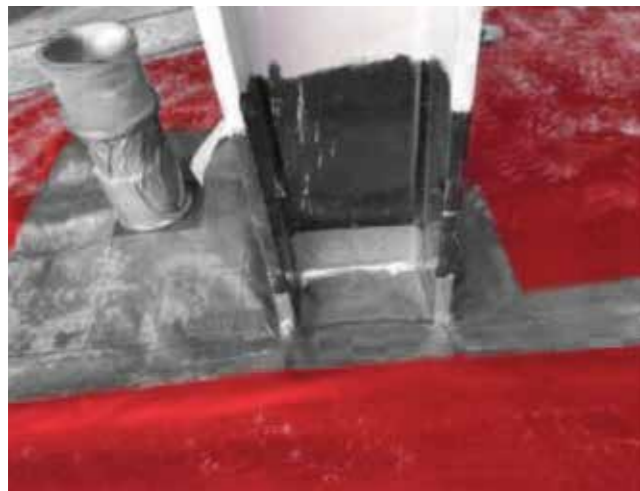

COLUMNS Apply Hydroprufe Primer. Leave to cure and seal using HCR Foil Girth Tape.

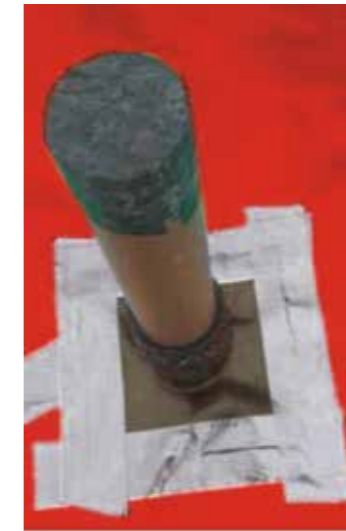

For multiple penetrations, Hydroprufe Tophats can be overlapped.



MEMBRANE PROTECTION



Protection board 300 to be installed to protect membrane from puncture. Spacer blocks can then be installed.





HYDROPRUFE DPM 2000G

Product Glossary

- pile head/pilecap preparation
- hydroseal FX mixing
- Hydroseal FX application
- Membrane application
- Protection Board application





PILEHEAD/PILE CAP PREPARATION



Substrates should be thoroughly jetwashed to remove loose material. Use airline to remove standing water.



MIXING



Mix one full bag of powder with one full container of liquid – no part mixing.



Pour all the liquid component into the bucket and then add the powder slowly to ensure continuous mixing.



Thoroughly mix for five minutes using mixing paddle.

APPLICATION



Ensure concrete is damp with no standing water and apply as a single 2mm thick coating. Ensure Hydroseal FX is applied to the sides of the pilehead to meet the blinding level.

HYDROSEAL FX COVERAGE GUIDE	
PRODUCT SIZE (2 PART) 30LTR	
COVERAGE UP TO 6.5 M ²	
450MM PILEHEADS	600MM PILEHEADS
x17	x11

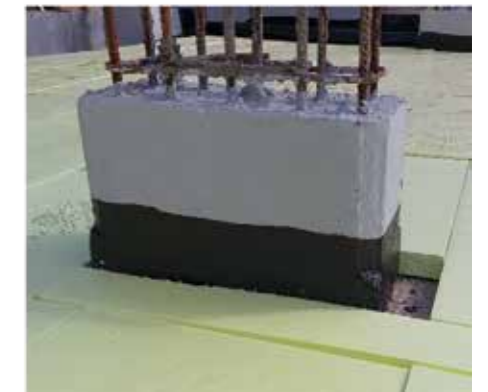

Apply 100mm strip of Hydroprufe Primer on top of Hydroseal FX where taped connections are required. Allow primer to cure.



Cut membrane carefully around the concrete profile, apply HCR Foil Girth Tape to connect the membrane to the Hydroprufe Primer.

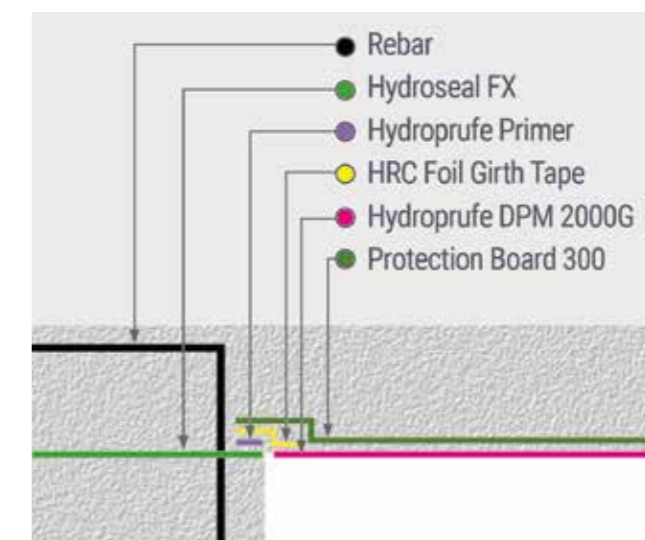

Detail shows section through a pilecap with application sequence as described above.

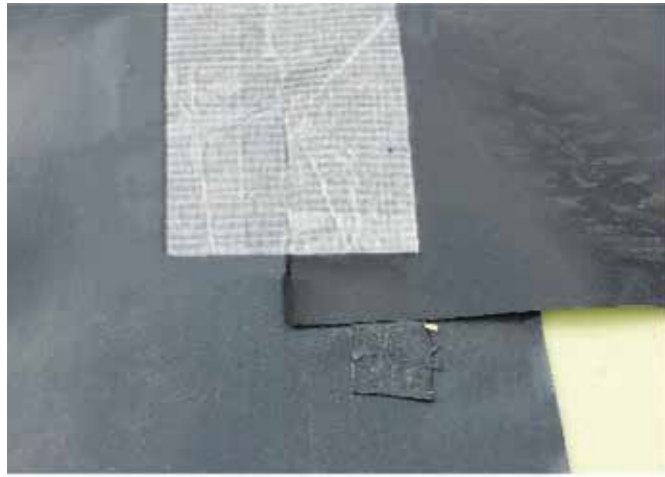

Minimum overlap should be 100mm. Laps to be sealed with 30mm HCR Butyl Tape within the lap and Girth Tape on the overlap. Laps should be rolled with a soft roller to ensure the tapes are fully bonded.

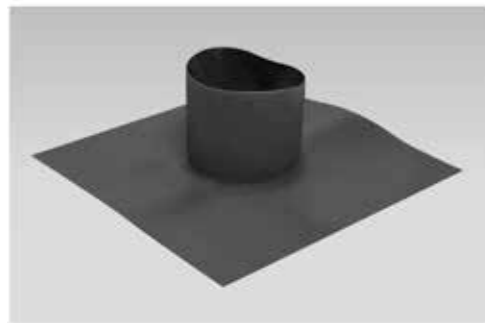

Seal penetrations to membrane using Hydroprufe Top Hats to suit diameter of penetration.

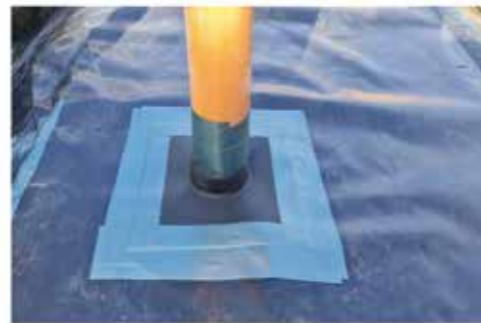

Tape flanges to membrane using HCR Foil Girth Tape.

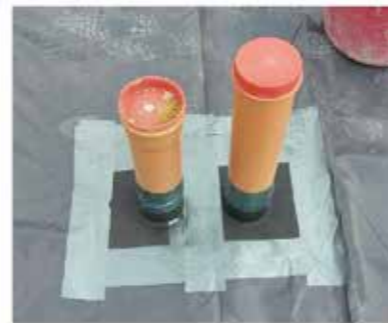

For multiple penetrations Hydroprufe Top Hats may be overlapped.



Protection Board 300 to be installed over the membrane to prevent damage from spacers and rebar.

HYDROPRUFE 3000 & 8000

Product Glossary

- Products required
- Substrate preparation
- Hydroprufe Primer application
- Membrane application
- Protection Board application





SUBSTRATE PREPARATION



Substrates should be jet washed to remove all loose material and any repairs carried out with Teknocem HBR.

Internal corners should have a 50mm x 50mm fillet of Teknocem HBR installed to ensure the membrane is fully supported.

HYDROPRUFE PRIMER APPLICATION



Pour Hydroprufe Primer into a suitable tray and apply to substrate with a roller.



The substrate should be thoroughly coated throughout with the Hydroprufe Primer. A second coat may be necessary on porous substrates.

MEMBRANE APPLICATION - RETAINING WALL



Mark a vertical line on the wall using a level. Cut the membrane to the length of the wall and remove the top 150mm of the backing paper. Adhere the membrane in place at the top of the wall ensuring that the membrane strip is vertical.



Laps in the membrane should be a minimum of 50mm wide.



Once membrane is installed, roll firmly with a lap roller to ensure that any entrapped air beneath the membrane is removed.



Install retaining bar when the membrane terminates on a vertical surface (not always required).

PROTECTION BOARD APPLICATION



Where drainage membrane isn't required, install Protection Board 600 in front of the self-adhesive membrane. This will ensure the membrane is protected when backfilling with soil/aggregates. Double sided tape can be used to adhere protection board.

HYDROFLOW HM8 - DRAINAGE MEMBRANE APPLICATION



Adhere Hydroflow HM8 drainage membrane to the vertical surface once self adhesive membrane has been installed, using high adhesion double-sided tape.



Only apply to horizontal surfaces where it remains continuous and directly joined to vertical sections, ensuring effective water management without unnecessary exposure.



Seal all joints using high adhesion single sided tape.



Use a geotextile membrane to encapsulate the land drain required.



Position a maintainable land drain at the base of Hydroflow HM8 and on top of the geotextile membrane.



Encapsulate the land drain with suitable granular fill.



Wrap the land drain and granular fill in the geotextile membrane.



With the land drain protected, backfill with soil or other substrate as required.

MEMBRANE APPLICATION - SLAB EDGE DETAILING



Example of Hydroflow HM8 installation



For slab edge detailing, follow the same procedures as outlined above for substrate preparation, primer application, membrane application, and protection with Protection Board 600, taking particular care to achieve neat, continuous coverage.



For best results, slab edge membranes should be applied as close as possible to the time of installing the brickwork façade or external cladding, as early installation without subsequent protection can leave the system vulnerable to site damage and compromise long-term performance.



All right-angle internal corners should be smoothly filleted using Teknocem HBR to eliminate sharp transitions and reduce stress on the membrane, while careful attention should also be paid to corners, changes in direction, and exposed slab edges to ensure the detailing remains tidy and robust.





HYDROFLOW HP

Product Glossary

- Products required
- Hydroseal sealer preparation
- Hydroflow HP8 application
- Hydroflow QS plugs application
- HCR butyl tape application
- Hydroflow corner tape application
- Hydrochannel application
- Hydroflow DPC application
- Hydroflow HP20

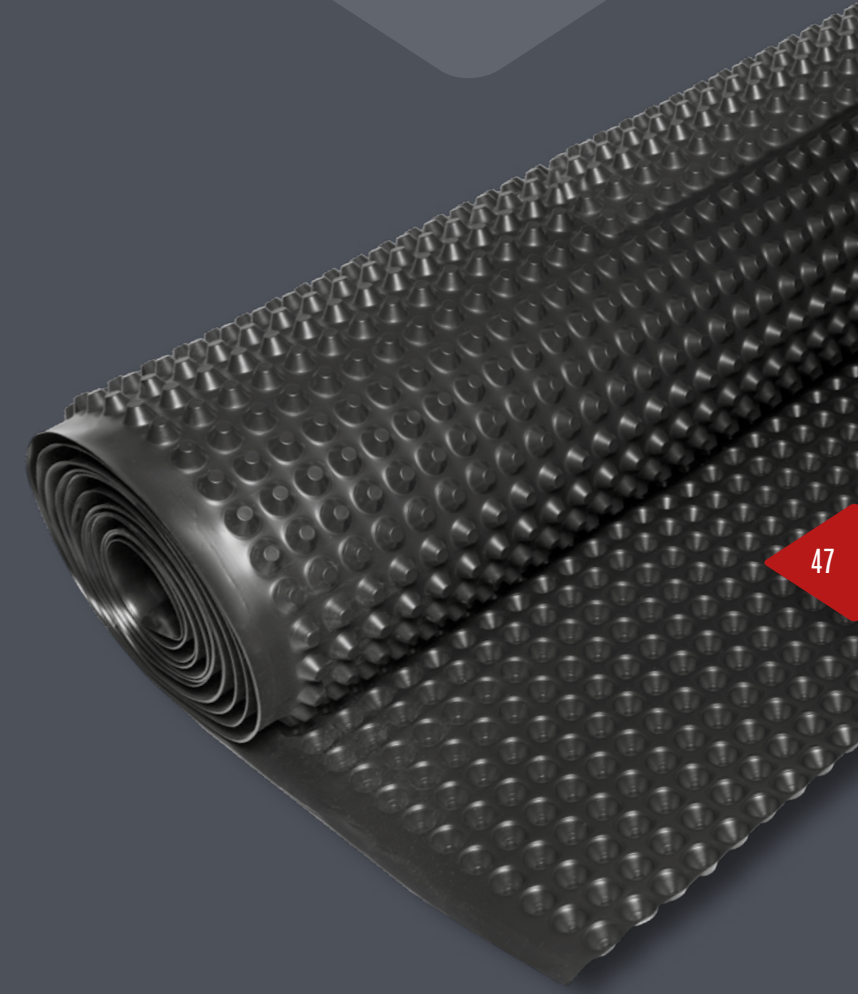



HYDROFLOW SEALING APPLICATION

Walls and slab should be pressure washed and any debris removed. Hydroseal Sealer should then be applied to the concrete. One 10Ltr tub will cover 40m².



HYDROFLOW HP8 APPLICATION



Measure from soffit to base of channel and deduct 20mm.



Cut Hydroflow HP8 membrane to length required.



Apply membrane to wall with studs against the concrete.

HYDROFLOW QS PLUGS APPLICATION



Drill 11mm hole through centre of stud around 70mm deep.



Fix Hydroflow QS plug ensuring it seals firmly to the Hydroflow HP8.



Fix at nominal centres of 600mm and in line with the block courses where relevant.

HYDROFLOW HCR BUTYL TAPE APPLICATION



Laps should be sealed with Hydroflow Butyl Tape, 100mm from the membrane edge.



Remove release paper and firmly push adjacent membrane to bond together.



Ensure laps are placed 200mm from the corner.

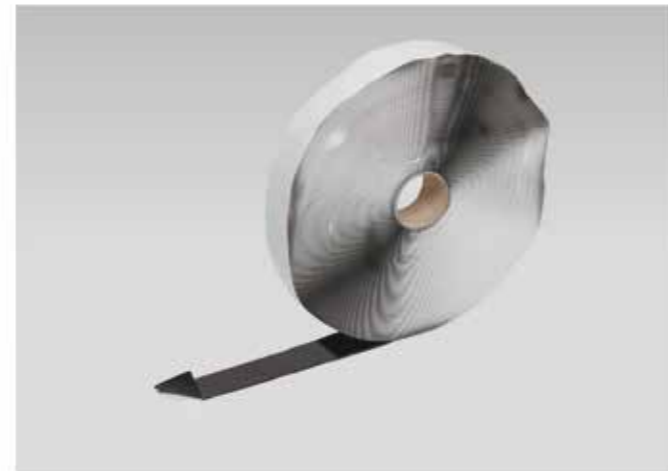

Hydroflow Butyl Tape.

HYDROFLOW CORNER TAPE APPLICATION



Apply 150mm Strip of Hydroprufe Primer to soffit. Leave to cure.



Using Hydroflow Corner Tape, seal the Hydroflow HP8 to the Hydroprufe Primer. Also overtape each membrane lap with Hydroflow Corner Tape.



HYDROCHANNEL APPLICATION

HydroChannel outlets should be installed as designed. Hydroflow Flushing Points should be installed at every change of direction or as designed.

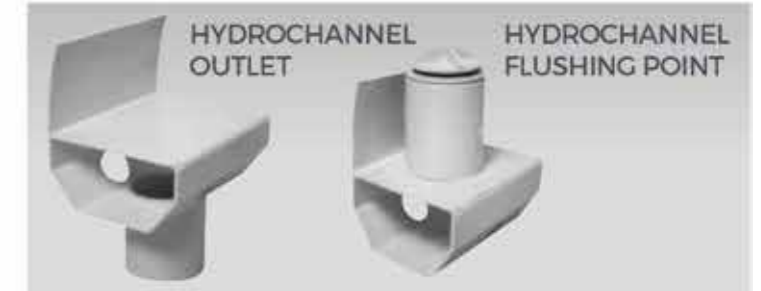

To join Hydrochannel corners, mitre the ends of channel at 45°.



Tape corners using Hydroflow Corner Tape.



Hydrochannel should be installed into the concrete rebate and the flange taped to the Hydroflow HP8.

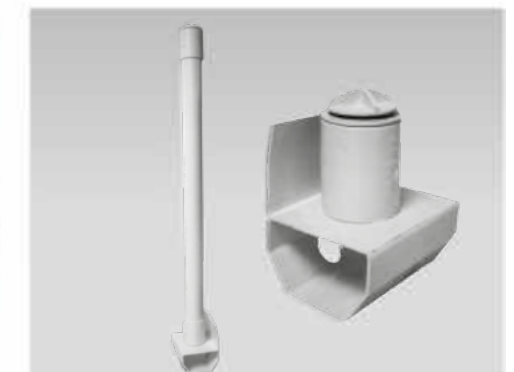

Hydrochannel Flushing Points can be extended using the flushing point extension piece.

HYDROFLOW DPC APPLICATION



Roll out Hydroprufe DPC and seal to the Hydroflow HP8 using Hydroflow Corner Tape around 300mm above the floor.



Cut a small perforation for the flushing point pipe and tape to the Hydroprufe DPC. Ensure DPC is firmly taped to the Hydroflow HP8.



Where designed, install engineering bricks at the base of the wall and ensure the perp joints are left open.



5mm diameter wall ties (Screw-in) can be used for brick/blockwork which are threaded into the pilot hole in the Hydroflow QS Plug.



HYDROFLOW HP20 APPLICATION



Recommended minimum access hatch size.



Roll Hydroflow HP20 out on the floor with studs facing down.



Apply strip of Hydroflow Butyl Tape to seal lap of Hydroflow HP20.



Remove release paper from Butyl tape.



Ensure that Hydroflow HP20 is overlapped by a minimum of two studs and pushed firmly down to ensure the lap is sealed.



Tape the Hydroprufe DPC to the Hydroflow HP20 using Hydroflow Corner Tape.



Once complete, Hydroflow HP20 is ready to receive floor screed.

CAVITY DRAIN ILLUSTRATION

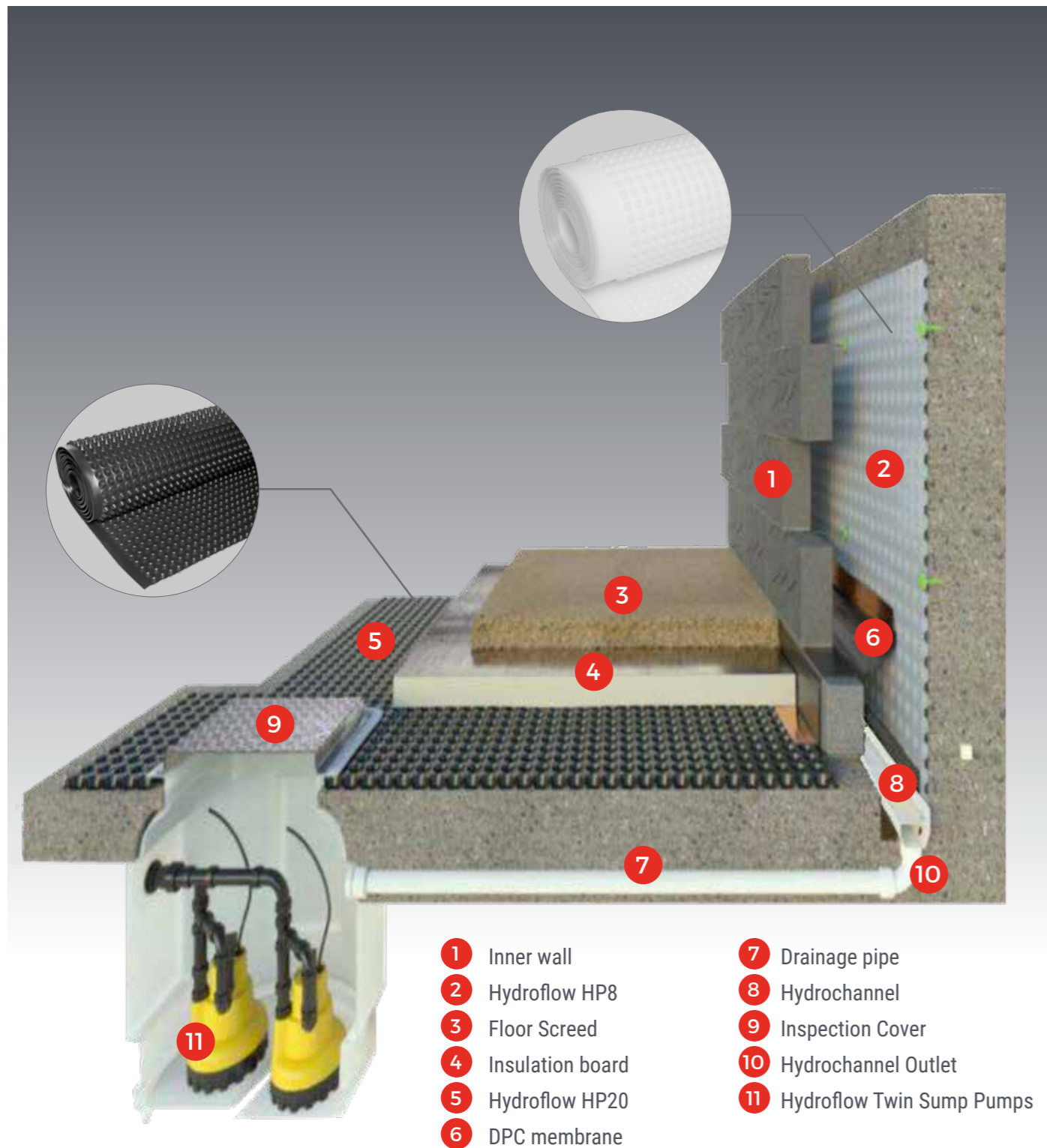

HYDROSEAL FX

Product Glossary

- Hydroseal FX Preparation
- Hydroseal FX mixing
- Hydroband 2000 application
- Hydroseal FX application





PREPARATION



First prepare the substrate using a high powered jetwasher held 100mm from concrete to remove any surface laitance.

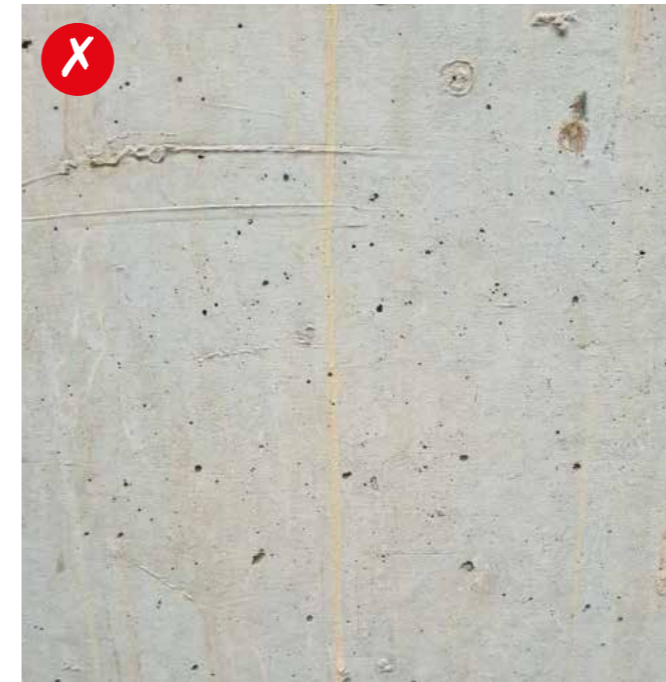

Example of a substrate prior to preparation.



Example of suitably prepared wall. Note that the surface is rough and aggregate exposed.



Mix the Teknocem HBR as per product instructions, and force into the gap with a gloved hand for initial contact coat, then build up flush with trowel.



Apply a 50 x 50mm fillet of Teknocem HBR at the interface between the wall and slab.





Surface prior to preparation. This substrate would not be suitable to receive a coating of Hydroseal FX.



Substrate should be prepared using Teknolevel FS.



Saturate the substrate with water using a suitable sprayer.



Teknolevel FS should then be used with a Trowel to fill in any pores on the face of the concrete.



To prepare the horizontal areas, a diamond grinder or powerful jetwasher should be used.



Example of correctly prepared substrate.



Hydroseal FX should be mixed with mechanical whisk using 1 tub of liquid to 1 bag of powder and mixed for at least 5 minutes to ensure the correct consistency. No part mixing is acceptable.



Use mechanical whisk only.



HYDROBAND 2000 APPLICATION



Hydroband 2000 is to be applied over any areas susceptible to cracking. Apply a 2mm layer of Hydroseal FX and embed the Hydroband 2000 into the layer. Then apply a second 1mm layer of Hydroseal FX over the top of the Hydroband 2000.

HYDROSEAL FX APPLICATION



Hydroseal FX can be applied by brush or trowel to a minimum thickness of 2mm. On vertical surfaces the coating will need to be applied in two 1mm layers to ensure a 2mm layer.



Hydroseal FX being applied by trowel.



Hydroseal FX can be troweled to a smooth finish if required.



A roller is NOT suitable for application of Hydroseal FX.

HYDROSEAL FX COVERAGE GUIDE

PRODUCT SIZE (2 PART)
30LTR

COVERAGE
UP TO 7.5 M²

EPOFLEX MMA

Product Glossary

- Epoprime MMA preparation
- Epoprime MMA priming
- Epoflex MMA mixing
- Epoflex MMA application





PREPARATION



Prepare any vertical surfaces using a high powered jet washer held 100mm from concrete or diamond grinder to remove any surface laitance and expose the aggregate. Use airline to remove standing water.



Break back areas of weak concrete to reveal a sound substrate.



To prepare horizontal areas, a diamond grinder or powerful jet washer should be used.



Vertical surfaces should be repaired with Teknolevel FS to achieve a pore-free surface. Apply using a trowel.



Apply 50mm x 50mm fillet of Teknocem HBR to internal corners. Flush with trowel.

PRIMING WITH EPOPRIME MMA



Concrete substrates should be primed using Epoprime MMA. This is supplied as a two-component system, base and catalyst. The product should be applied with a brush or roller at a rate of 0.4 – 0.8 Kg/m². The surface profile of the substrate will greatly affect the application rate that is achieved.

Allow the primer to cure for a minimum of 45 minutes before application of the EPOFLEX MMA commences. Primer is not normally required for application to asphalt and tarmac substrates.

MIXING EPOFLEX MMA

Mixing: EPOFLEX MMA is supplied as a two-component system, consisting of a Base and Catalyst component. The catalyst should be mixed into the base component using a mechanical mixing paddle for at least two minutes until a uniform consistency is achieved.



EPOFLEX MMA COVERAGE GUIDE

PRODUCT SIZE (2 PART)
1KG, 5KG, 10KG

COVERAGE
APPROXIMATELY 2M², 9M², 10M²
@ 2MM THICK

APPLICATION



EPOFLEX MMA is supplied in two grades. The Vertical Grade is for use on upstands and for detail work, whilst the Horizontal Grade is for application to horizontal deck areas. Typically, upstands and detail work is carried out before the horizontal deck areas are coated.

EPOFLEX MMA should be applied immediately once mixed onto the prepared substrate and spread to the minimum thickness (1mm) using a roller (approx. 0.75kg/m²). A floor scraper can also be used to spread the EPOFLEX MMA.

Once the first coat has been applied and the correct level has been achieved, the Fibremat reinforcing layer should be embedded into the wet coating. Laps between adjacent sheets of Fibremat should be 50mm.



Immediately after the Fibremat has been embedded a further minimum thickness (1mm) of EPOFLEX MMA should be applied before de-aerating with a spiked roller.



Where new wet EPOFLEX MMA is being applied to existing dry EPOFLEX MMA, allow for 100mm overlap. If a non-slip finish is required, then an appropriate quartz aggregate should be broadcast into the freshly applied coating at a rate of 6-15kg/m².



Once the membrane is hardened the excess aggregate may be swept off. If the membrane is to be left exposed, then it should be sealed using EPOSEAL MMA to provide a sealed surface which is easily cleaned.



SPARK TESTING

The EPOFLEX MMA should be spark tested immediately prior to the drainage membrane being installed to ensure that the coating is defect free.

HYDROFLOW HM25 DRAINAGE MEMBRANE

HYDROFLOW HM should be fixed to the outside of the structure to provide an effective drainage void. If the HYDROFLOW HM is to provide a drainage void against a PREMCRETE waterproof membrane then it should be adhered to the membrane using HYDROPRUFE HCR BUTYL TAPE 100mm width to secure the HYDROFLOW HM in place until backfill has taken place. If the HYDROFLOW HM is to be installed directly against concrete or masonry, then it may be fixed mechanically at 1 metre centres. Laps between adjacent sheets are created by butt jointing the membrane sheets before folding the geotextile membrane lap against the adjacent sheet. This will ensure that no soil fines can penetrate the geocomposite membrane which may result in clogging.

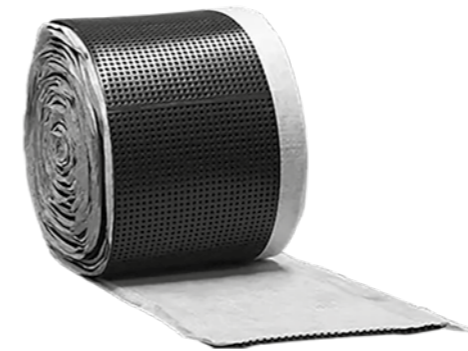



HYDROREND

Product Glossary

- Products required
- Substrate surface preparation
- Hydrorend mixing
- Hydrorend application





SUBSTRATE - SURFACE PREPARATION



Brick surfaces should be prepared using a sand blaster or high-powered jet washer to remove all coatings and loose material.



The substrate should be thoroughly saturated prior to the application of the Hydrend. Care should be taken to ensure there is no standing water prior to application.

MIXING



Approximately 2.5 Litres of clean water should be mixed with one 25kg bag to achieve the desired consistency. The mortar should typically be mixed for 3 minutes.



Hydrend should be mixed using a forced action paddle mixer.

APPLICATION



Hydrend should be applied to a minimum thickness of 5mm and a maximum thickness of 50mm ensuring that it is worked into the wall to provide a good bond. The initial coating should be keyed and then left to stabilise prior to applying subsequent coatings.



Cureaid AC should be applied to the surface of the Hydrend before it has cured.

HYDROREND COVERAGE GUIDE

PRODUCT SIZE
25KG
COVERAGE
UP TO 1.4 M² @ 10MM THICK
YIELD
14.4LTRS PER 25KG BAG



HYDROBAR

Product Glossary

- Preparation
- Hydrobar welding
- Hydrobar fixing

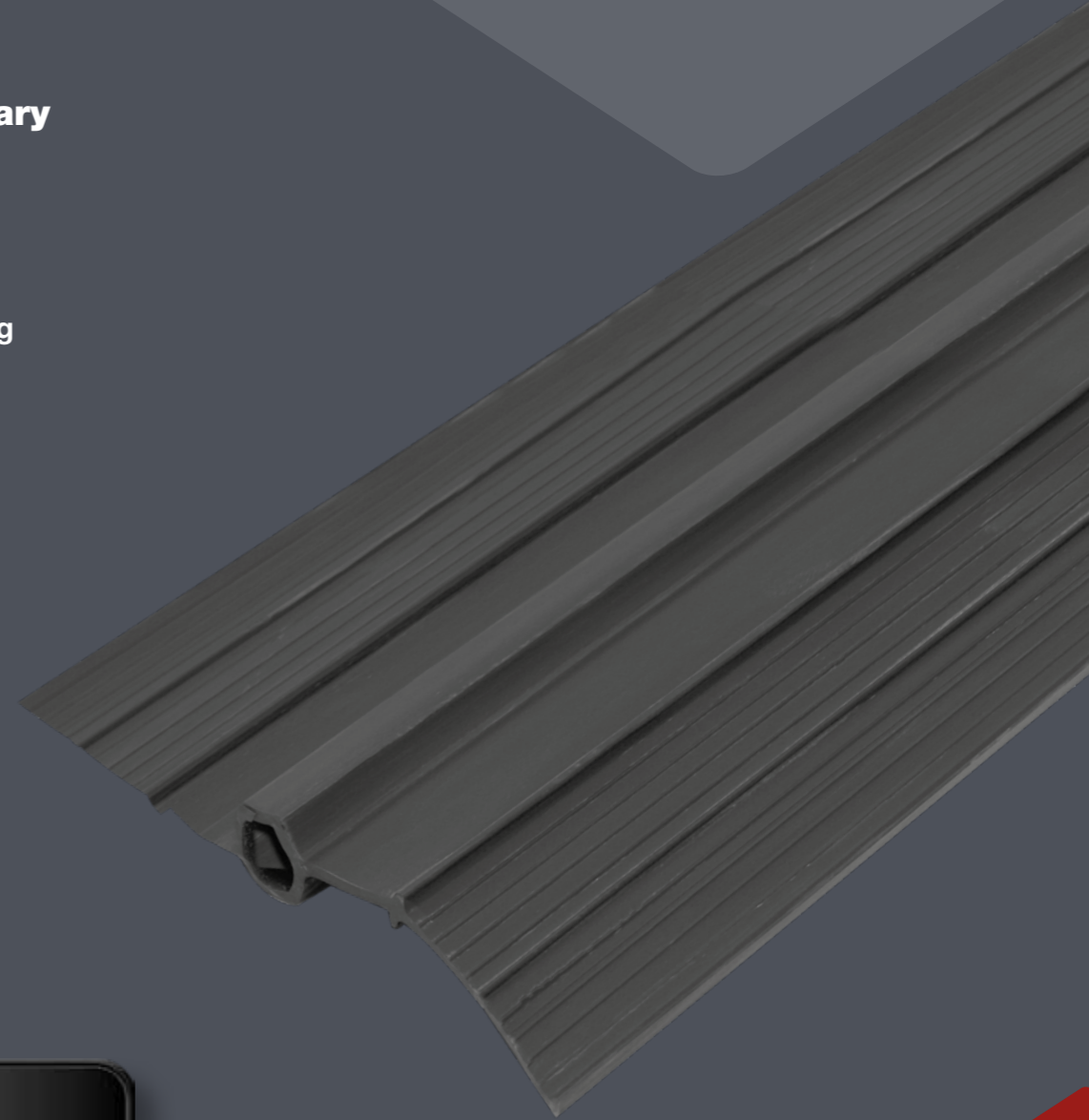

Premcrete recommends Specialist Installers are employed to install this system. Contact your Project Manager for recommendation of a suitable Specialist Installer.

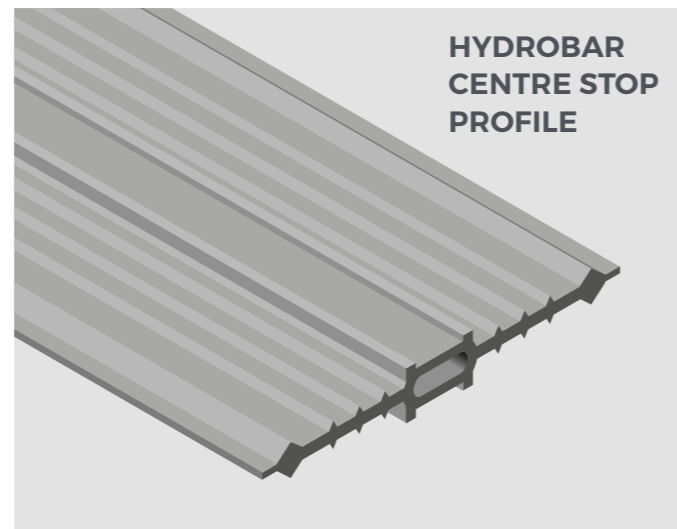
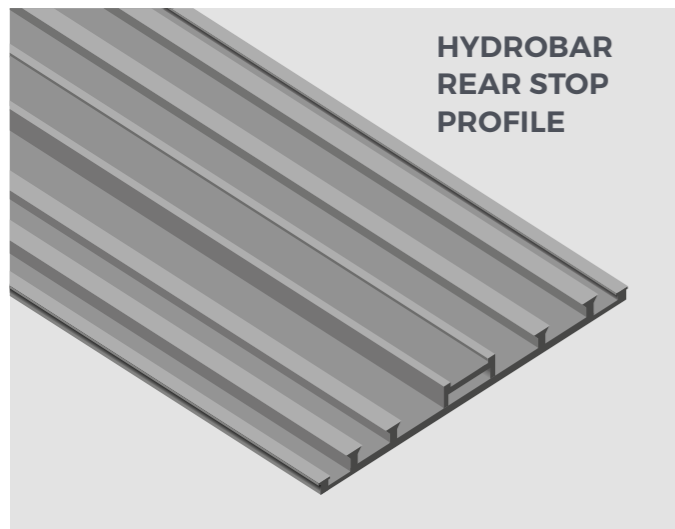
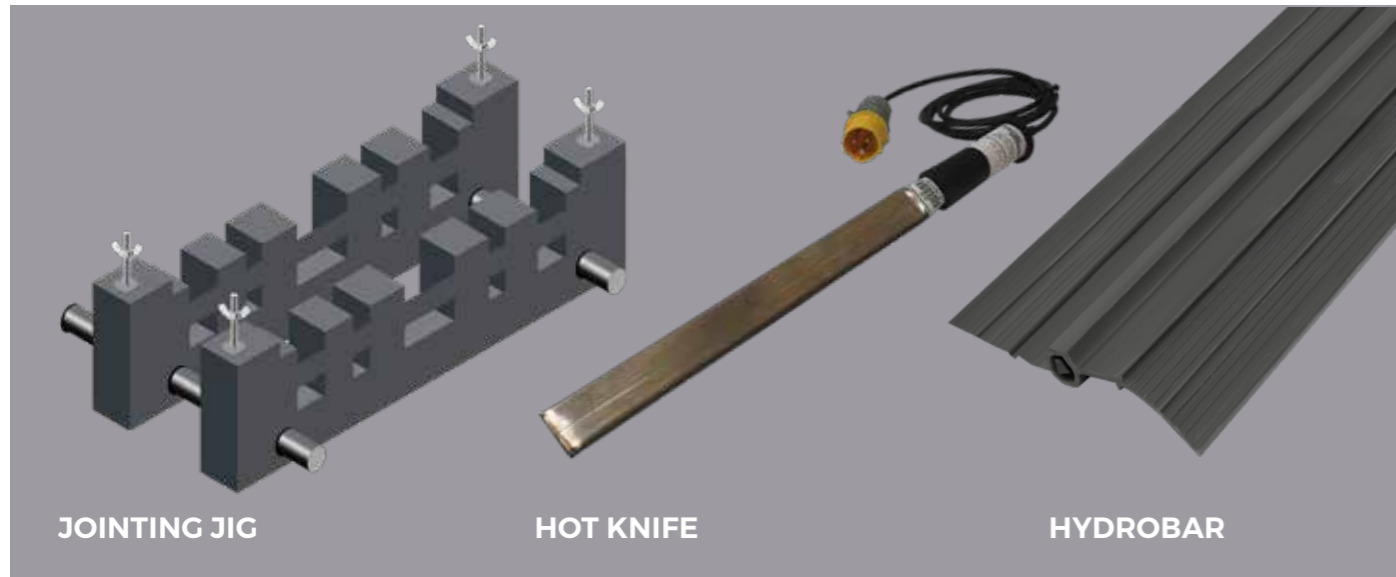

JOINTING PREPARATION



Lay Hydrobar onto the jointing jig.

Tighten jig firmly leaving 10mm of the Hydrobar protruding.

WELDING



Position the hot knife between the ends of the Hydrobar and slide the second Hydrobar into the hot knife.

Once the Hydrobar has begun to melt, remove the knife and slide the joint together to connect the two melted ends. Hold jig firmly for 20 seconds.

Remove the jig and inspect the weld. A small ridge should be along the weld. Ensure that the joint is completely welded with no holes.

FIXING



Hydrobar should only be fixed through the flanges onto a firm flat substrate such as a concrete.



Exafoam board should be installed against the shutter and then pour the concrete.



HYDROBAND HP TO MOVEMENT JOINT

Product Glossary

- Products required
- Substrate Preparation
Preparation for priming
- Preflex EP
Mixing and application
- Eponite EP
Mixing and application
- Hydroband HP
Application
- Hydroband DPC and
Teknocem HBR Application

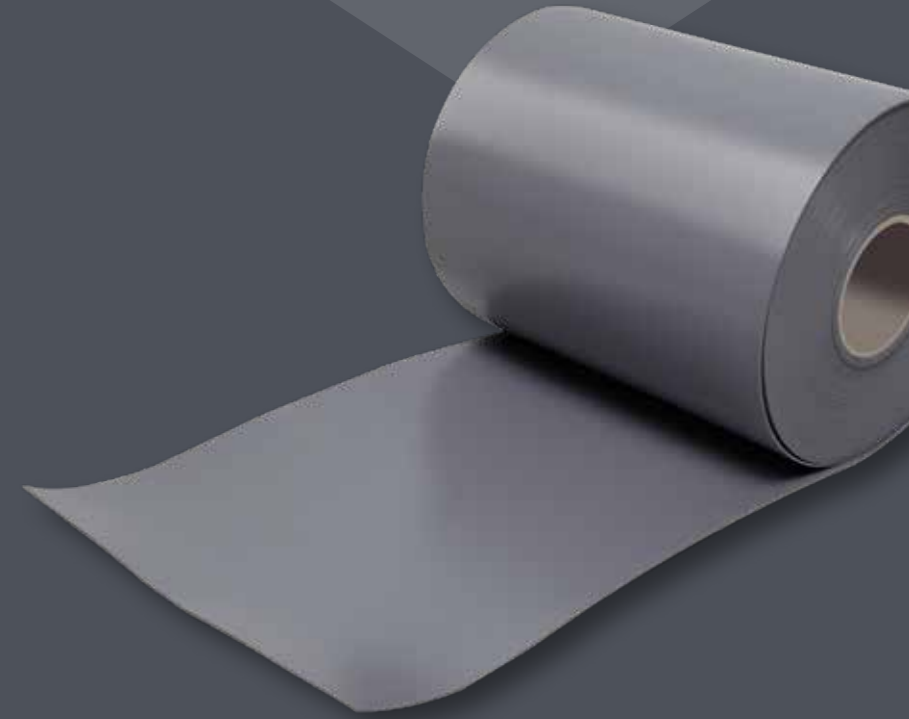



PREPARATION

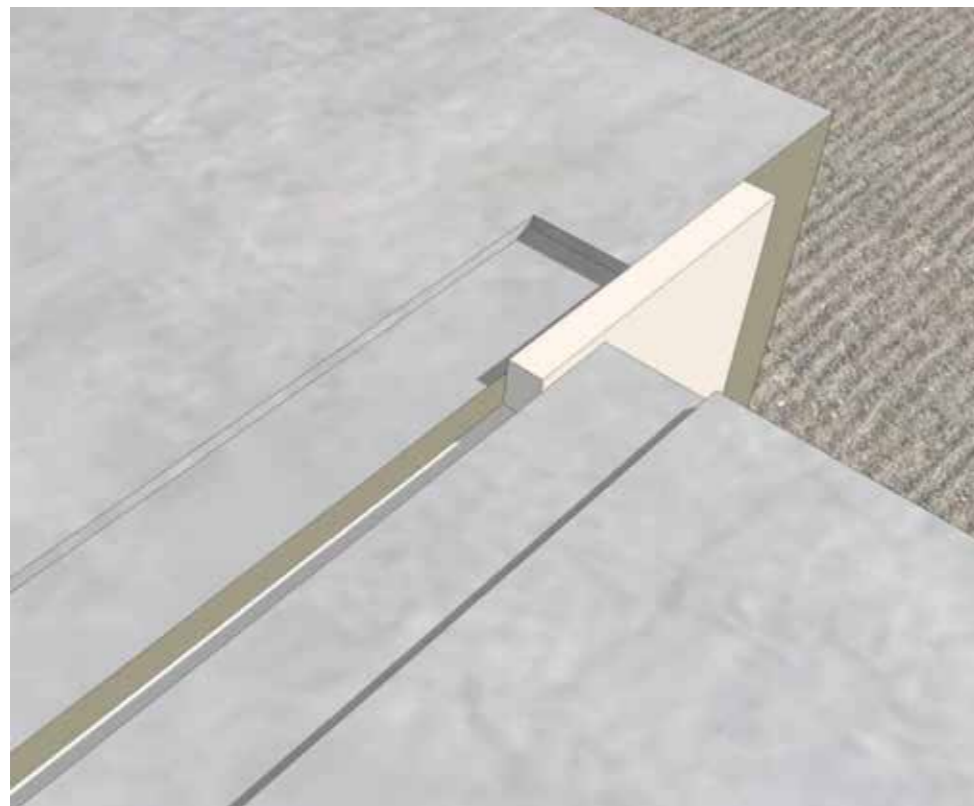

Prepare the area around the movement joint by breaking out a 10mm deep by 150mm wide rebate. The Exafoam filler should be removed to a depth of 25mm deep to create a square rebate.

PREFLEX EP MIXING AND APPLICATION

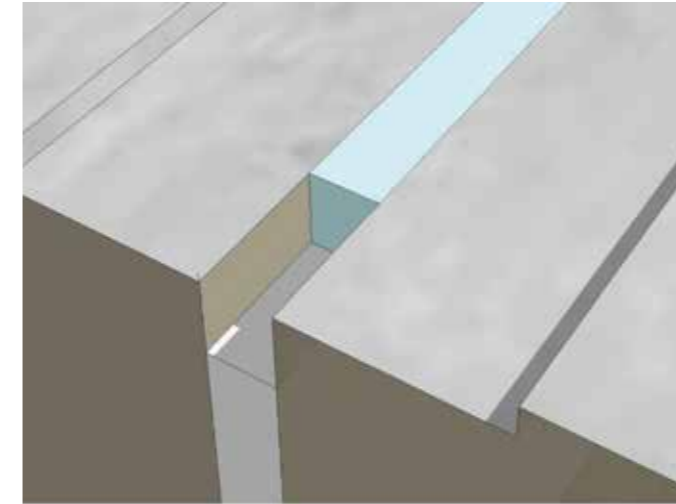

Preflex EP is a two component joint sealant which is mixed by pouring the curing agent into the base and mixing thoroughly using a low speed drill and paddle mixer until a uniform consistency is achieved. Fill the rebate with Preflex EP and trowel off 10mm from the top of the concrete. Allow the Preflex EP to cure for a minimum of 24 hours prior before continuing with following stages.

EPONITE EP MIXING AND APPLICATION

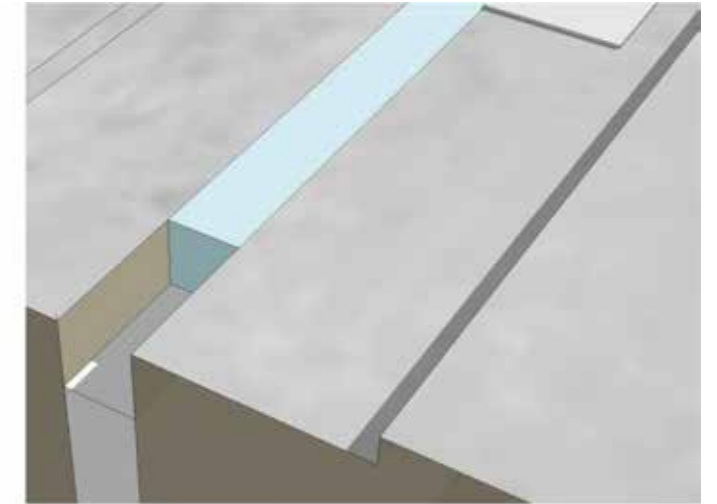

Install a debonding tape over the joint sealant. Eponite EP is a two component epoxy adhesive - base and curing agent. Thoroughly mix together using a slow speed drill with paddle attachment, until a uniform grey mixture has been produced. Apply a 1mm layer of the adhesive extending a minimum of 50mm either side of the 25mm rebate. Ensure the Eponite EP is spread out beyond the width of the Hydroband HP. Once complete, remove the debonding tape to expose the joint sealant and keep clean from Eponite EP.

HYDROBAND HP APPLICATION

Hydroband HP is a thermoplastic membrane, available in a variety of widths.

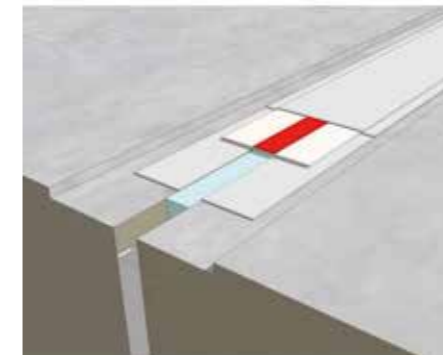

Apply a debonding tape to the centre of the Hydroband HP and then install carefully along the centre of the movement joint. Firmly press the Hydroband HP1 into the Eponite EP ensuring a 'slack' of membrane is compressed into the recessed joint. A small headed concrete nail can be used to pin the Hydroband HP1 into place at this stage if required.

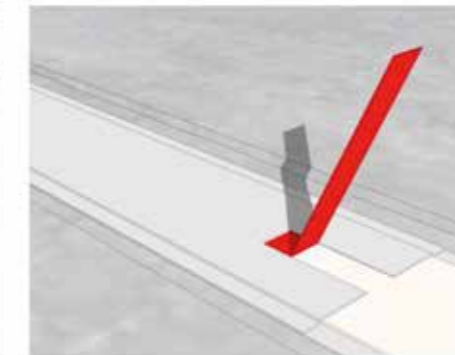

Apply another layer of Eponite EP over the top of the Hydroband HP and then carefully peel off the debonding tape to remove the adhesive from the centre of the Hydroband over the movement joint. Eponite EP will cure in around 10 - 12 hours.



This photo shows the tape being removed from the Hydroband HP. Removing the adhesive from the centre of the Hydroband will allow it to flex as the joint expands/contracts.

HYDROPRUFE DPC AND TEKNOCEM HBR APPLICATION

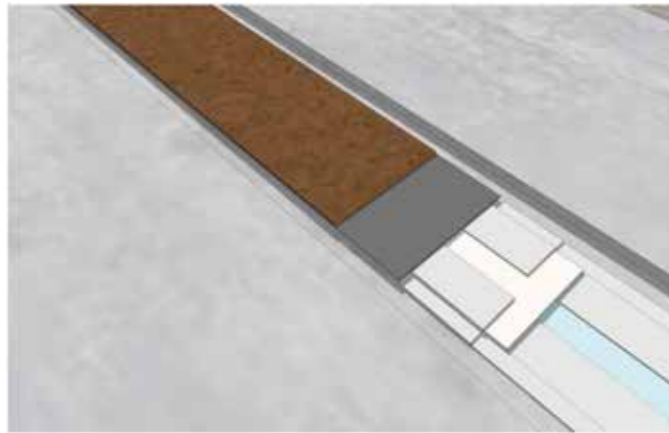

Once the Eponite EP has fully cured, a strip of Hydroprufe DPC should be installed on top as a debonding strip for subsequent layers.

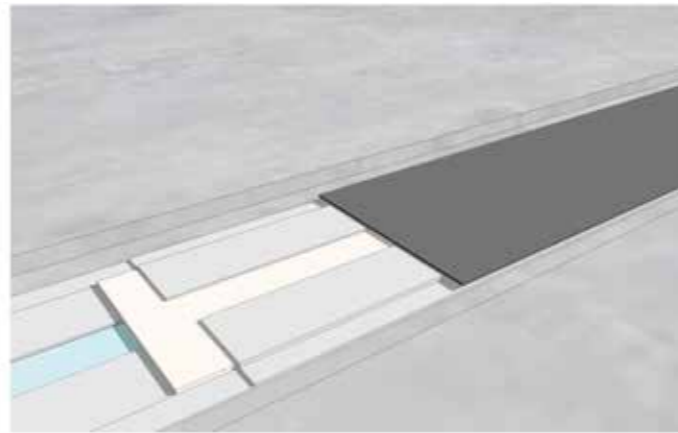

Install a thin layer of Teknocem HBR on top of the Hydroprufe DPC to provide a bed for the steel plate.

STEEL PLATE APPLICATION

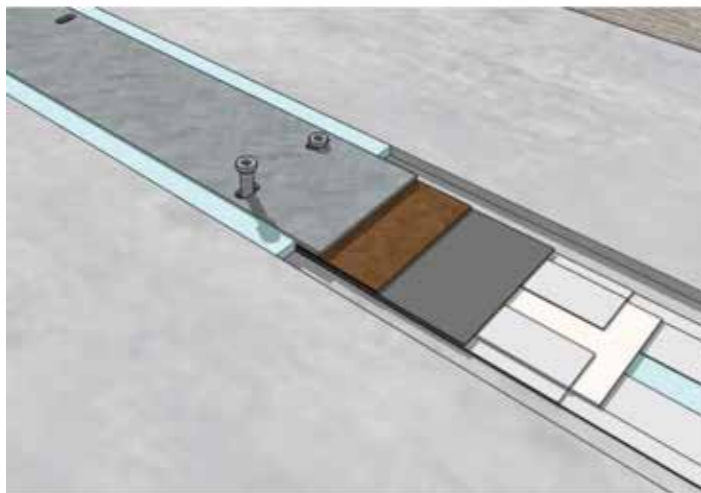

Bed the steel plate onto the Teknocem HBR and fix down firmly through the slotted holes with M8 fixings. Fill in the recesses between the edges of the plate and concrete with a fillet of Preflex EP.

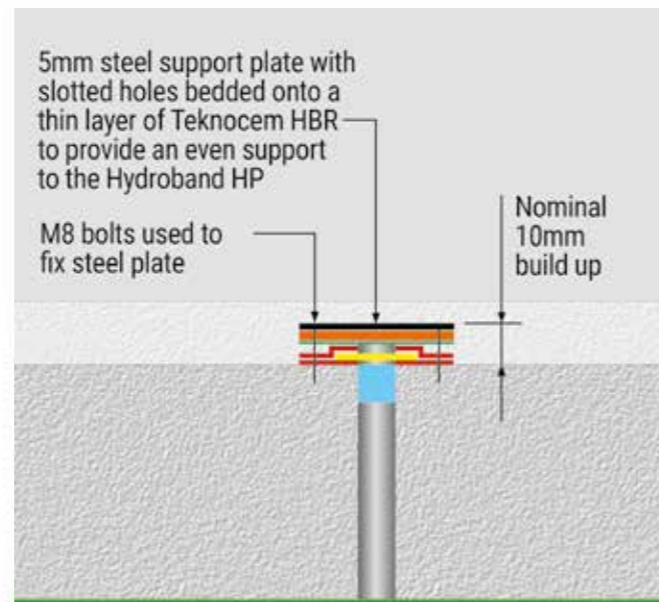

Cross section through movement joint.

VOID-TEK GROUND HEAVE PROTECTION

Product Glossary

- Products required
- Preparation
- Application



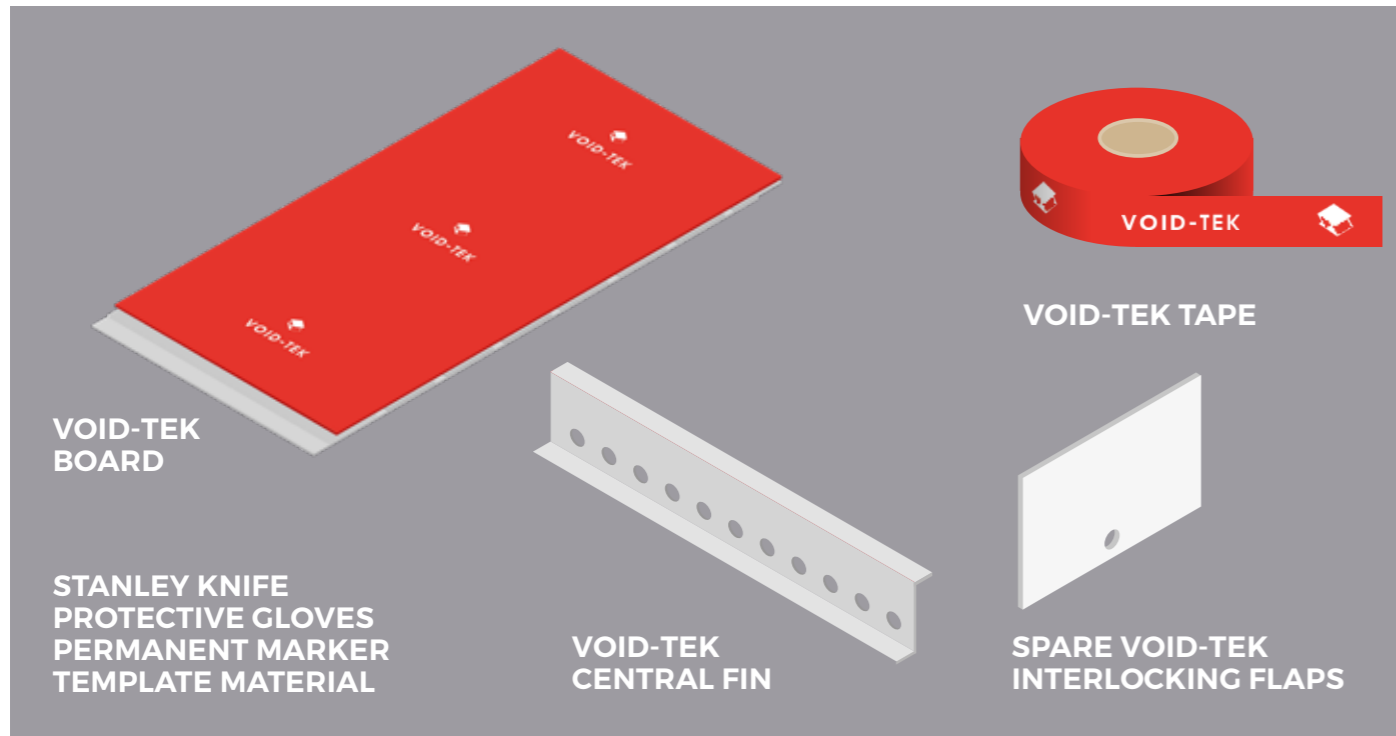

PREPARATION



Place the Void-Tek flat panels near to installation area.



Lift top of Void-Tek panel to full height.



Pull down the interlocking flaps and lock into the slot provided.



Sweep debris from concrete binding surface prior to laying Void-Tek panels.

INSTALLATION



Set out and measure the area intended for Void-Tek positioning.



Accurately measure the pile cap diameter.



Create a template for the pilehead or pile cap and place in position on the Void-Tek panel.



Once in position, mark up the areas to be cut with a permanent marker.



Cut the top of the board with a Stanley knife and expose the area below.

PLEASE WEAR SAFETY GLOVES AS MATERIAL CAN HAVE SHARP EDGES ONCE CUT.



Remove the top section to reveal the structure below.

INSTALLATION



If there is a structural fin revealed below, cut it with a stanley knife and also remove the interlocking flap.



Mark out the bottom sheet and cut out with stanley knife. Remove all waste material.



As the structural strength will be compromised, apply the spare interlocking flaps to create new internal supports.



This will ensure the panel is again structurally sound to take the weight of the concrete.



So, the required interlocking flaps are now in place.



To strengthen and support the front edge, cut one of the spare internal fins to size.

INSTALLATION



Fold and place into position closely to edge of the cut hole.



Carry Void-Tek to the installation area with required assistance.



Place in position, lowering over the pile.



Continue to place all Void-Tek panels to cover the required area.



Once all panels are butted together in position, seal all edges with Void-Tek tape.

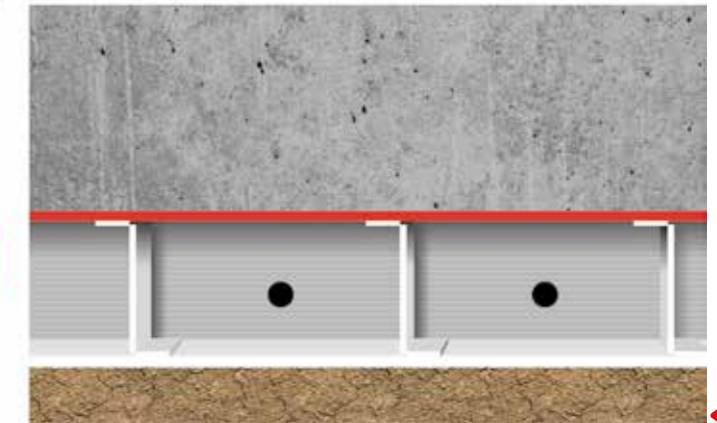

The area is now prepared for the concrete pour.

INSTALLATION

Tolerances for cutting VOID-TEK panels

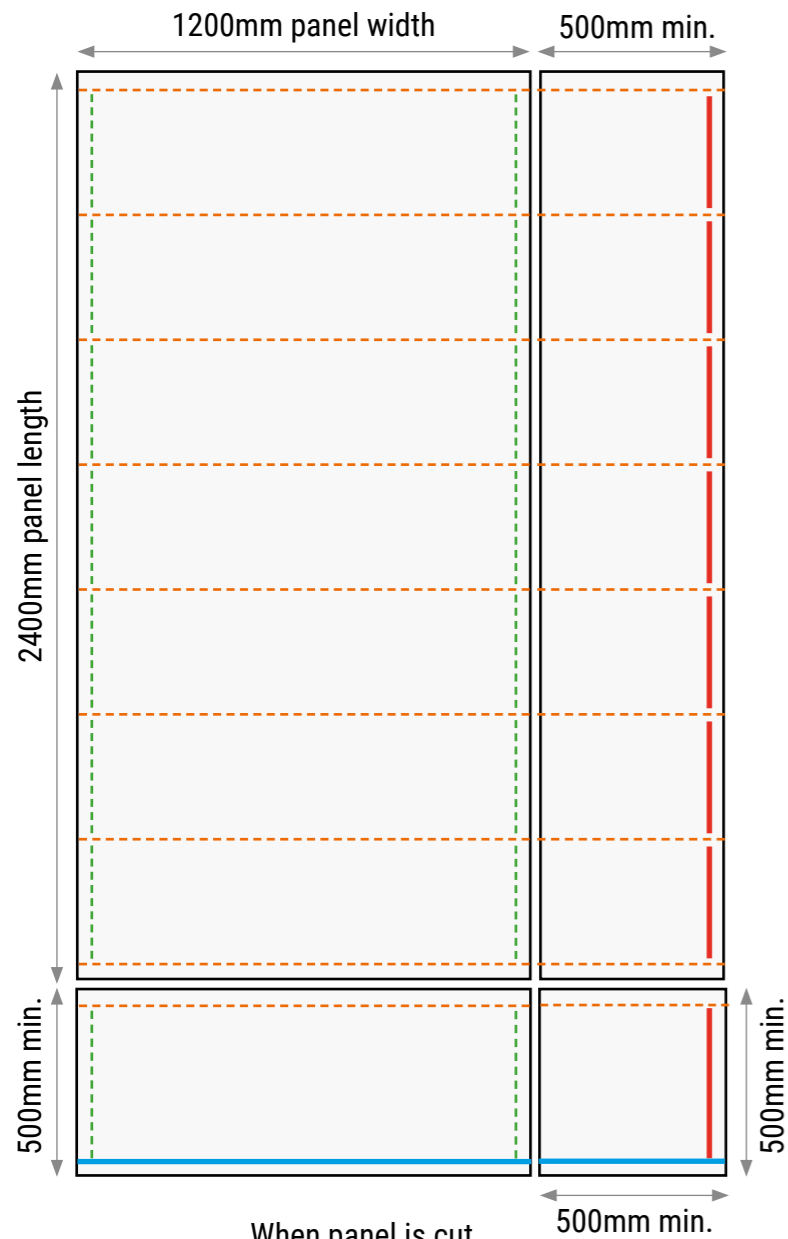

Tolerances for cutting VOID-TEK panels

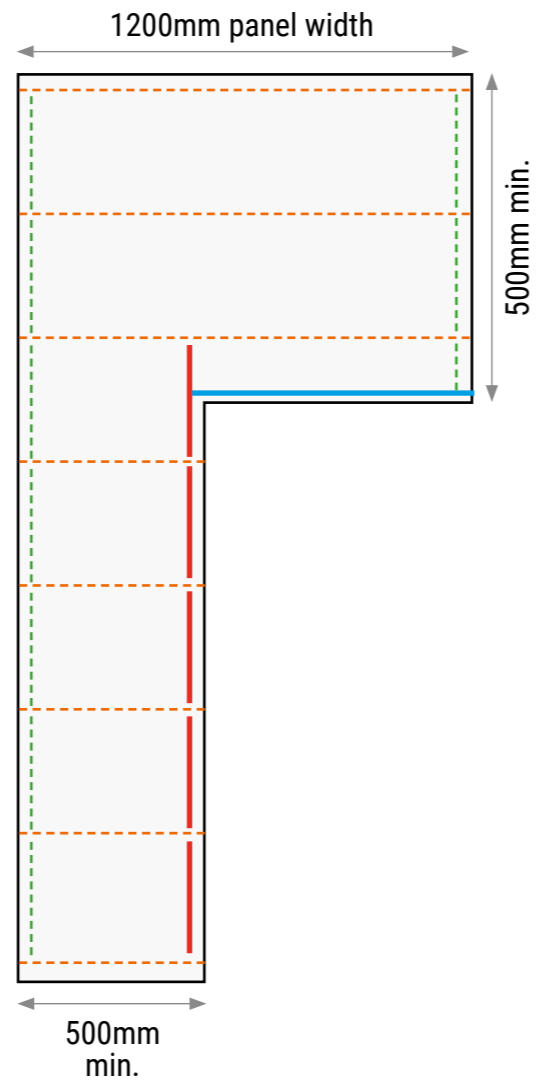

When panel is cut insert Interlocks between the Fins

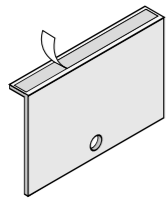

- - - Pre-fitted Structural Fins
- - - Pre-fitted Interlocks
- Replacement Interlocks
- Replacement Structural Fins

INSTALLATION

Tolerances for placement around piles

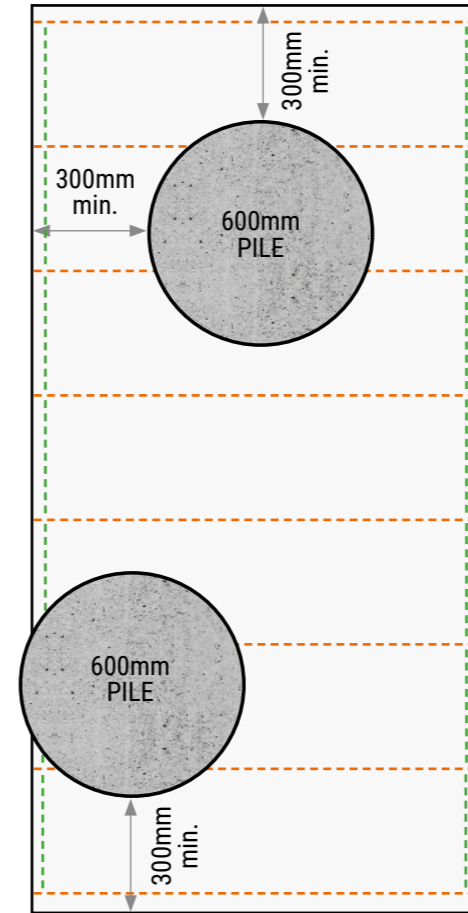

Build up of fins and interlocks around piles

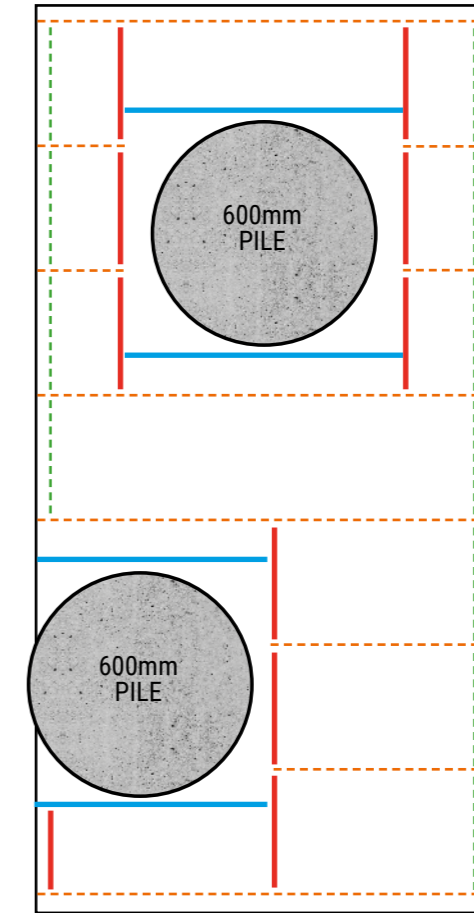

Build up of fins and interlocks around piles of different sizes

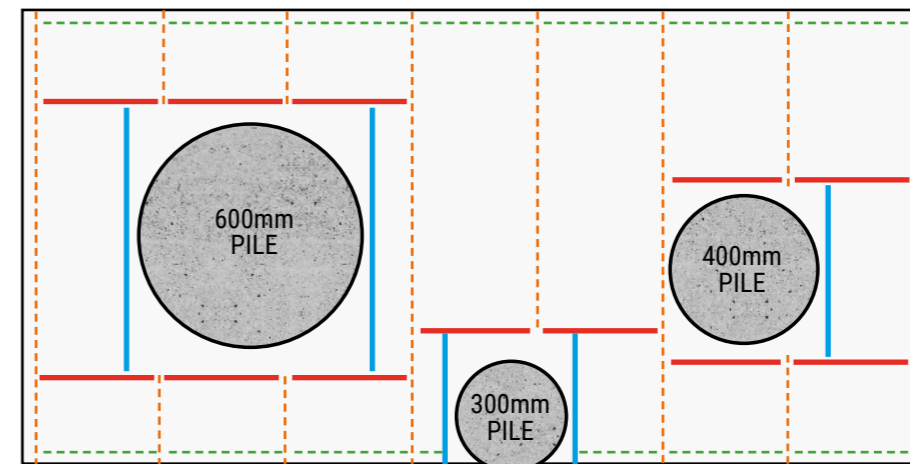

PROTECTING
COMPLEX
STRUCTURES



PREMTRAC QUALITY CONTROL PORTAL

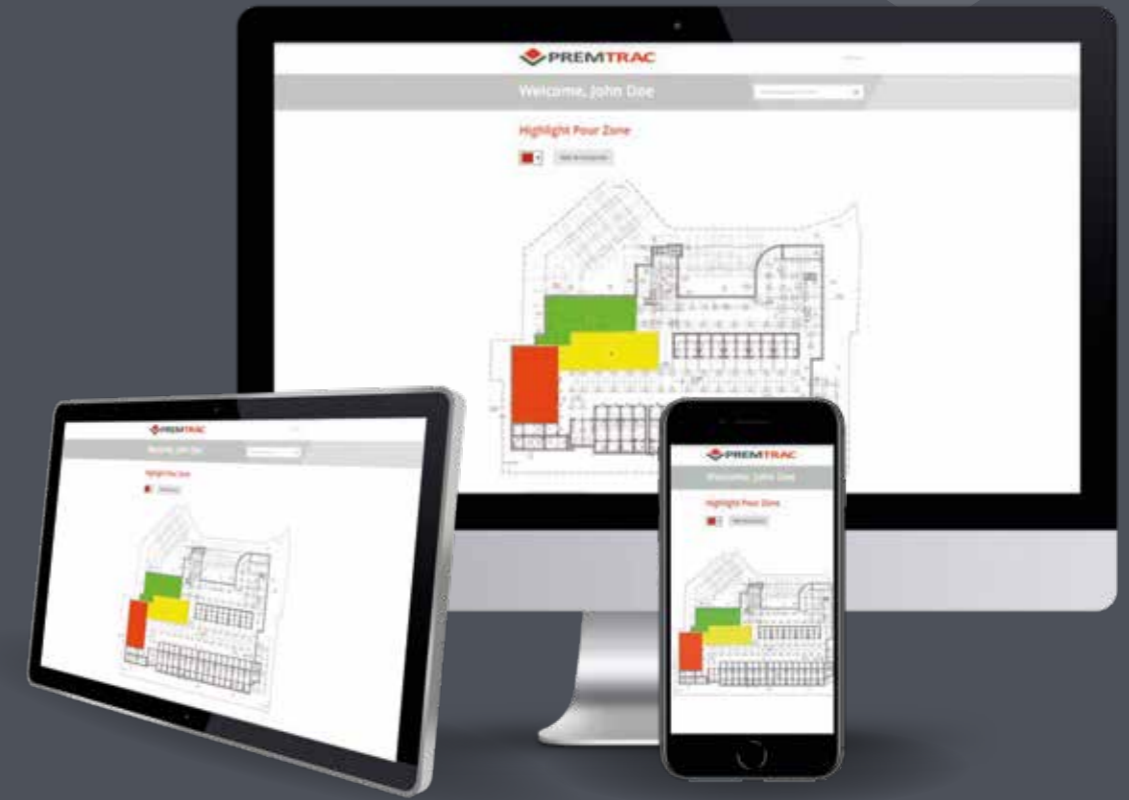

The web portal is of a bespoke design, to assist both ourselves and the contractors for the management of quality on any project.

Upon commencement of a project, any relevant party is provided with login details to be able to access information pertaining to their project.

COMMUNICATIONS

All critical project related communications are uploaded onto the portal for all to view and for an accurate record to be kept of the date etc

CONTRACTOR QUALITY CONTROL

As the installation of the waterproofing system progresses, the contractor should login to the Premtrac portal and notify Premcrete of upcoming concrete pours and the like so as to keep the Premcrete technicians updated as to when site visits are required. Once the waterproofing is completed, in a specific zone then the nominated person on site, responsible for monitoring the quality of the installation, will complete the QC report on the system using the Tablet provided by Premcrete.

The Contractor's Quality Checker is responsible to mark up on the floor plan the zone of work that has been completed, within Premtrac, and then complete the electronic quality report. Photographs are then attached to specific points on the floorplan showing the quality of workmanship. Once completed, it is saved and can then be viewed on the portal as linked to the specific zone. The floorplan can be "drilled into" to access photographs and QC reports for any given zone as the work is completed.

When any report is completed, everyone linked to the project receives a notification email with a link to the report. The Premcrete technician responsible for the project can then monitor the installation as it proceeds.



PREMCRETE QUALITY CONTROL

Premcrete technicians visit site frequently (with particular emphasis at the outset of the project) to monitor the installation of the waterproofing system. Premcrete complete a QC report for each visit, in the same way as described above. Again, all reports are fully traceable, and photographs are attached to the floor plan accordingly.

NON-CONFORMANCE REPORTS

Any non-conformances that are found by Premcrete during site visits are recorded using the Premtrac system. An electronic report and photographs of the issue is recorded by Premcrete using the NCR module within Premtrac. This is issued to the contractor who is then responsible to close out the NCR report by correcting the issue and submitting photographic evidence that the issue has been resolved. The Premcrete technician receives an electronic copy of the report and can then close out the NCR once complete. There is a register on Premtrac showing all NCRs and what date they have been closed out.

PROJECT COMPLETION

Once the project has been completed, all information stored on the Premtrac Portal can be downloaded as a single zip-folder for use in compiling the O & M manual. Information included in the final download is as follows:

- Technical datasheets
- Method statements
- Technical drawings
- Photographs
- Safety datasheets
- Training registers
- QC Reports
- Non-Conformance Reports
- Non-Conformance close-out Reports
- Floor plan with cross reference to QC
- Reports and photographs
- All Project Correspondence.

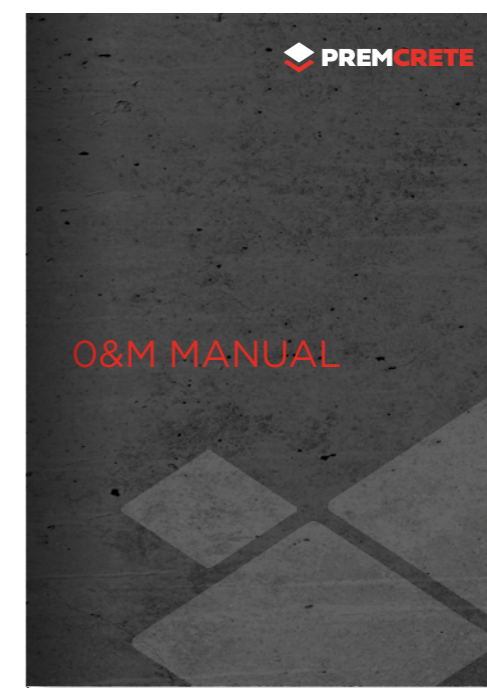

PROTECTING
COMPLEX
STRUCTURES



CONCRETE POURING & COMPACTION



AT A GLANCE GUIDE

BASED ON A 6M WIDE BY 4M HIGH WALL

- 1 Set up 4 pokers across the concrete pour width.
- 2 Pokers must be turned on before the first concrete pour, then raised after each pour, leaving 50mm of the poker in the curing concrete prior to the next pour.
- 3 This process is repeated after each pour, until the 5 pours are complete. Avoid repeatedly lifting and dropping the pokers to avoid additional air bubbles occurring within the concrete.
- 4 Use pencil pokers and/or formwork vibrators during each pour to remove air bubbles in areas not accessible by larger pokers

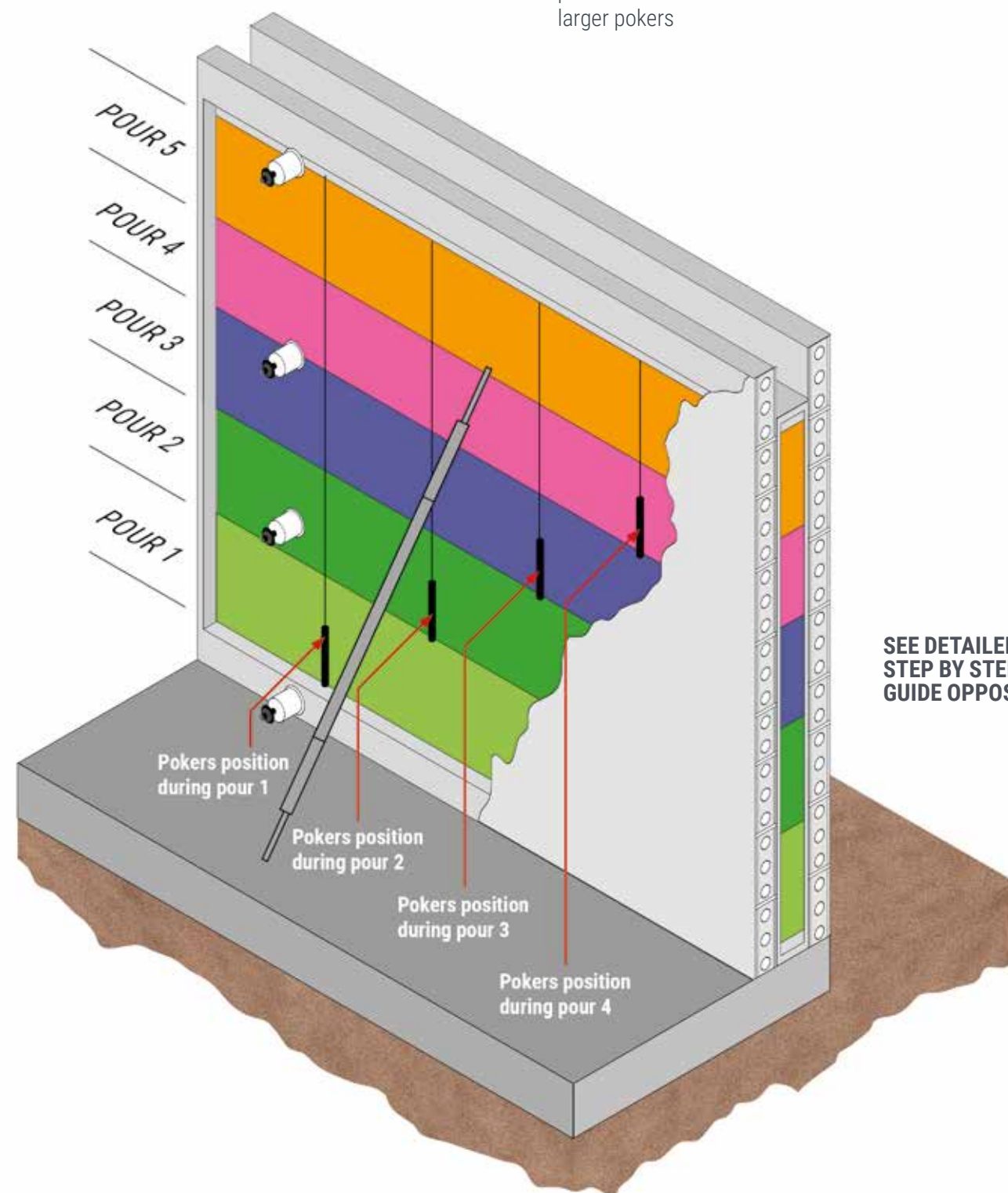

STEP BY STEP GUIDE

BASED ON A 6M WIDE BY 4M HIGH WALL

Upon arrival of the concrete wagon, carry out a slump test before you start pouring. This ensures the concrete has the right consistency. If you're unsure, call the technician. Never add water to the concrete on site.

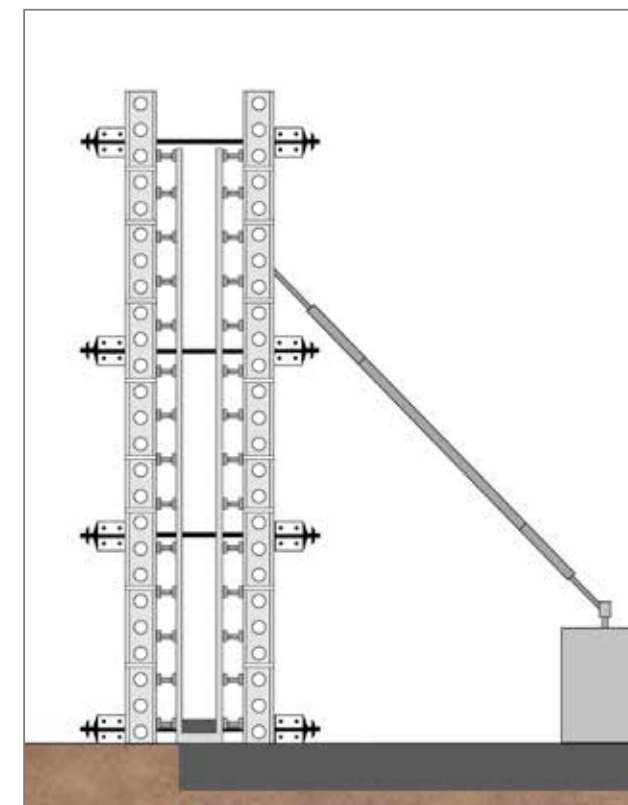

Erect the formwork

Erect the wall formwork / shuttering ready for the concrete pour. Ensure shuttering panels, soldiers, ties and supports are clean, straight and are free of damage. Make sure the base slab or footing is clean and level for accurate alignment.

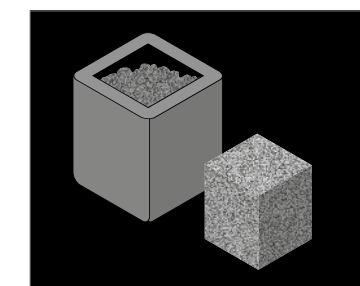
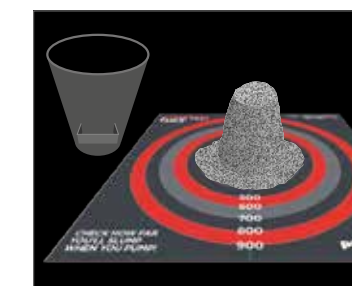

Slump Test on arrival

Every time a concrete wagon arrives, carry out a slump test before you start pouring. This ensures the concrete has the right consistency. If you're unsure, call the technician. Never add water to the concrete on site.

Take cube samples

Take cube samples as required for testing the concrete's strength later on. Make sure the correct procedure is followed when collecting samples.

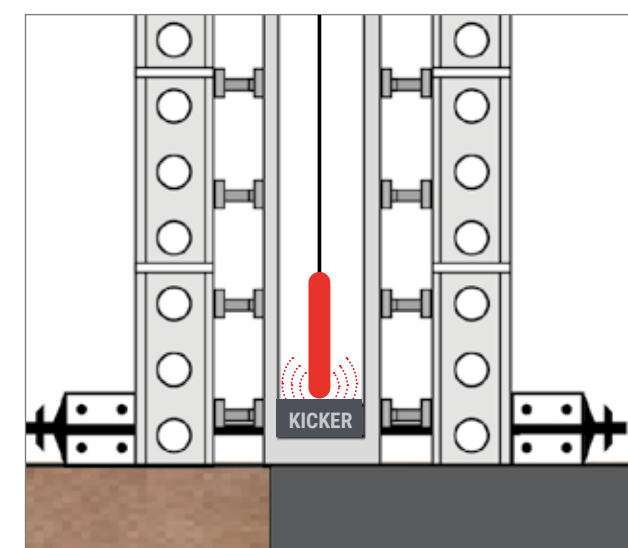

Turn on vibrating pokers

Once the concrete mix is correct, drop 4 no. 65mm pokers evenly along the length of the 6 metre wall pour. Before any concrete goes into the wall, make sure all pokers are turned on and working. Pokers help remove air and compact the concrete properly.

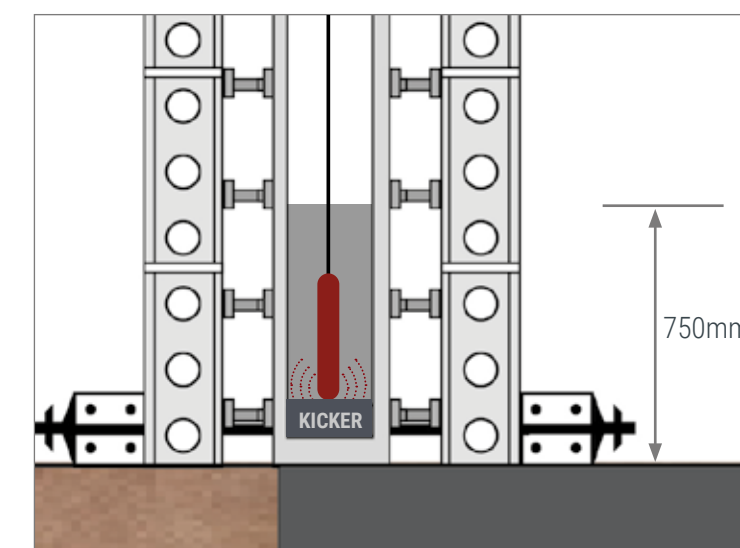

Pour the first concrete layer

Pour 2 skips of concrete into the wall - each skip holds 0.7m³, so together that's 1.4m³. This amount will fill the wall to around 750mm high. Do not move the pokers during this first layer until the bubbles stop rising, the concrete settles and the pitch of the vibrator changes. 5-15 seconds is a guide but visual control is critical.

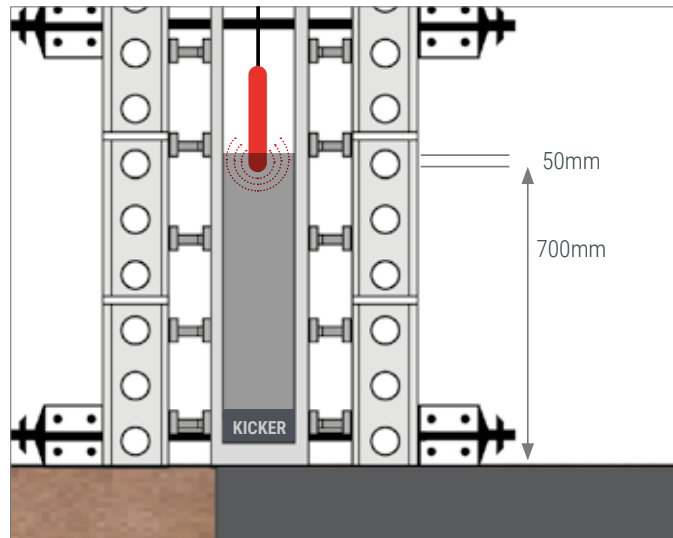

Raise the pokers

Once the first layer is poured, raise the pokers up by 700mm. The tip of each poker should still sit 50mm inside the top of the wet concrete. This keeps the compaction consistent between layers. Avoid repeatedly lifting and dropping the pokers, as this may introduce additional air bubbles into the concrete.

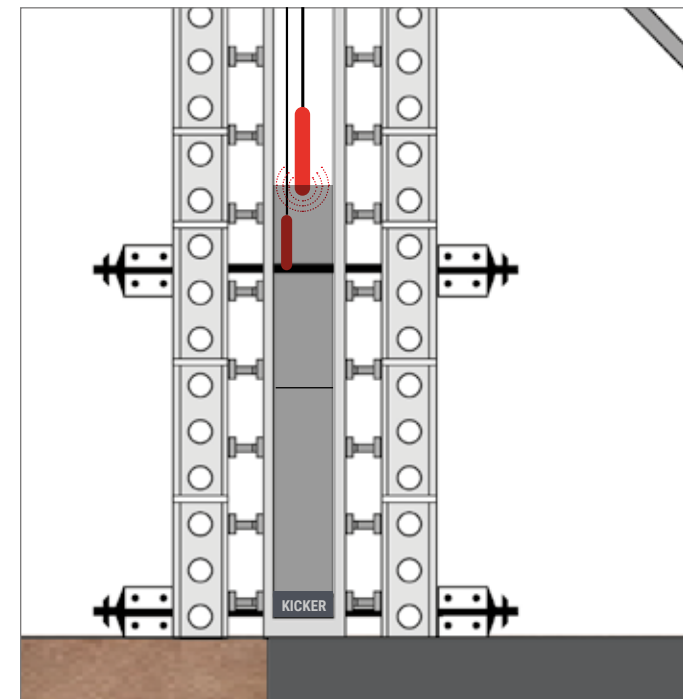

Repeat for each layer

Keep repeating the process:

Pour 2 skips (1.4m³)

Raise the pokers 700mm (keeping them in the top 50mm), and use the pencil poker as before.

You'll pour 5 layers in total, each about 750mm high.

Remove the pokers once the fifth layer has been poured.

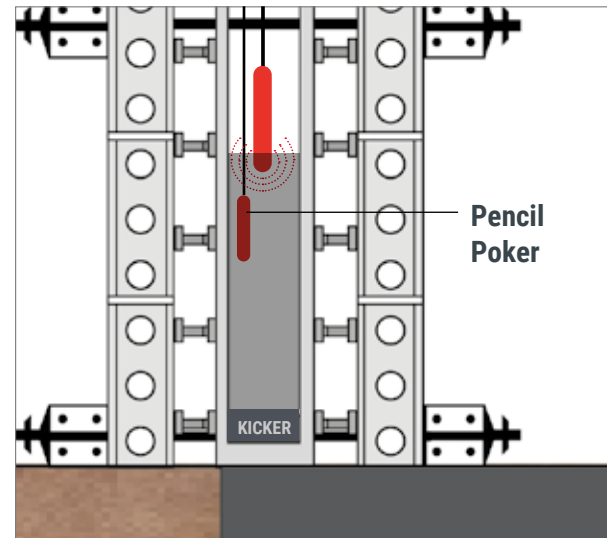

Use pencil pokers or formwork vibrators

After each layer is poured and the main pokers are in position, use a pencil poker to remove any trapped air bubbles. Focus especially around edges and tight areas where the bigger pokers might not reach. Once the pokers are inserted avoid repeatedly lifting and dropping them as this may introduce additional air bubbles into the concrete. The use of a formwork vibrator can also be used particularly for thin, heavily reinforced or inaccessible walls where pokers cannot reach.

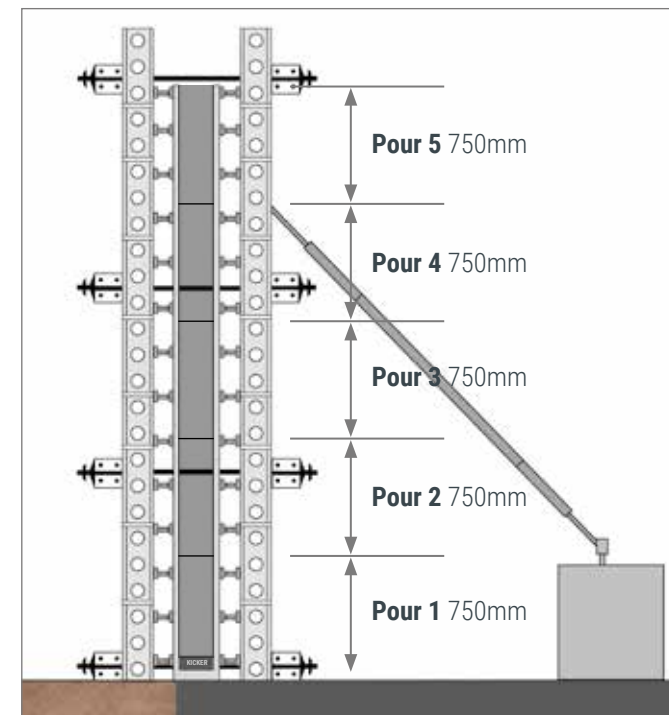

Complete the wall

After 5 layers, the wall will be around 3.75 to 4 metres high.

This will use a total of 10 skips of concrete.

Check the surface finish and make any final adjustments.





**THAT SHOULD COVER IT...
NOW YOU KNOW HOW.**

44 Macadam Way | West Portway
Andover | Hampshire | SP10 3XW

www.premcrete.com
02380 276166
sales@premcrete.com



PREMCRETE

PROTECTING COMPLEX STRUCTURES